

# PRACTICAL WORK IN GEOGRAPHY

PART I  
TEXTBOOK FOR CLASS XI

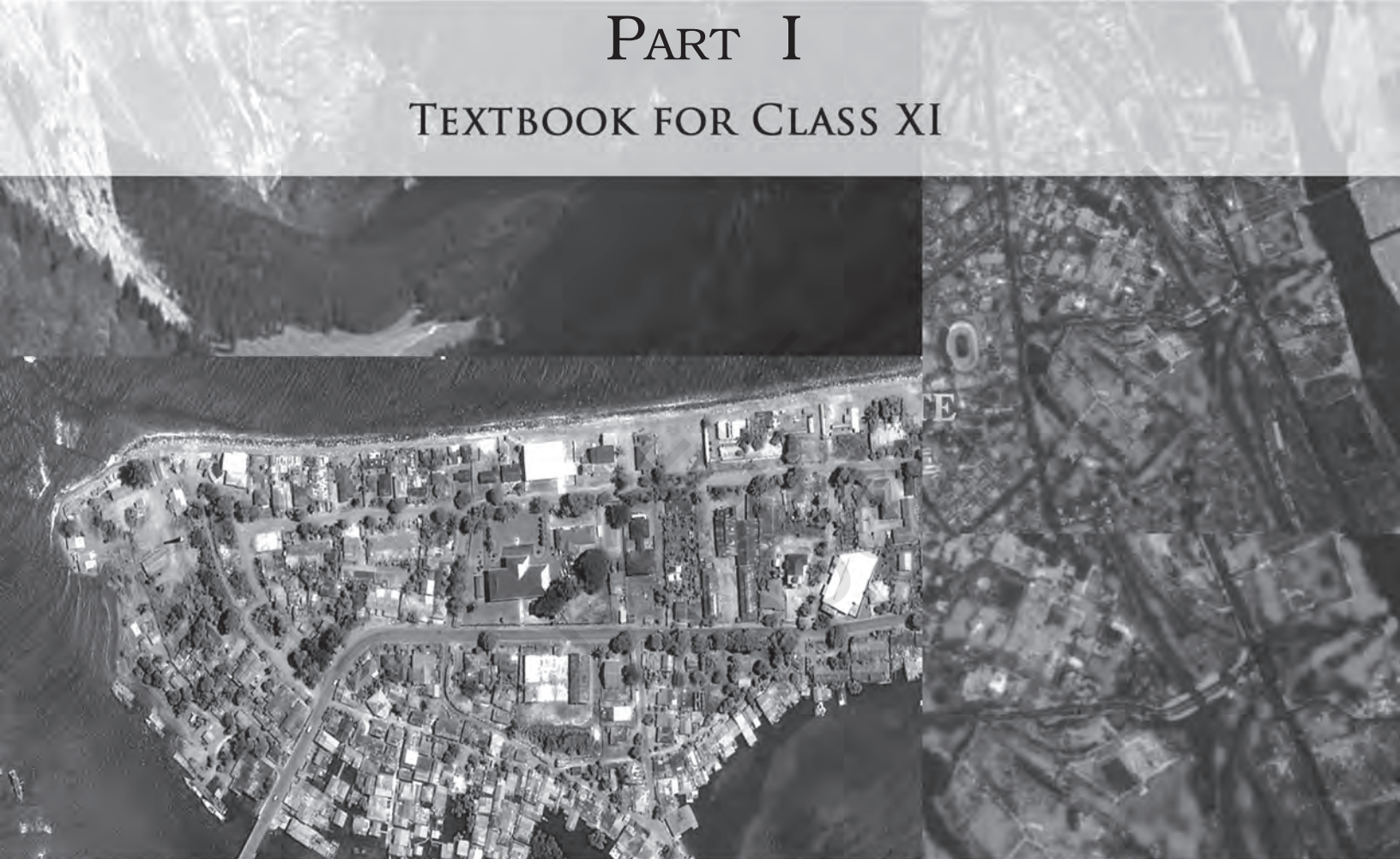

11096

विद्यया ऽ मृतमश्नुते



एन सी ई आर टी  
NCERT

राष्ट्रीय शैक्षिक अनुसंधान और प्रशिक्षण परिषद्  
NATIONAL COUNCIL OF EDUCATIONAL RESEARCH AND TRAINING

**First Edition**

June 2006 Asadha 1928

**Reprinted**

February 2007, December 2007,  
May 2008, February 2009,  
January 2010, January 2011,  
November 2013, December 2014,  
March 2016, February 2017,  
November 2017, December 2018,  
August 2019, December 2021

**Revised Edition**

October 2022 Kartika 1944

**Reprinted**

March 2024 Chaitra 1946

PD 60T SU

© National Council of Educational  
Research and Training, 2006, 2022

₹ 100.00

Printed on 80 GSM paper with NCERT  
watermark

Published at the Publication Division by the  
Secretary, National Council of Educational  
Research and Training, Sri Aurobindo Marg,  
New Delhi 110 016 and printed at Dee Kay  
Printers, 5/34, Industrial Area, Kirti Nagar,  
New Delhi 110 015

**ALL RIGHTS RESERVED**

- No part of this publication may be reproduced, stored in a retrieval system or transmitted, in any form or by any means, electronic, mechanical, photocopying, recording or otherwise without the prior permission of the publisher.
- This book is sold subject to the condition that it shall not, by way of trade, be lent, re-sold, hired out or otherwise disposed of without the publisher's consent, in any form of binding or cover other than that in which it is published.
- The correct price of this publication is the price printed on this page. Any revised price indicated by a rubber stamp or by a sticker or by any other means is incorrect and should be unacceptable.

**OFFICES OF THE PUBLICATION  
DIVISION, NCERT**

NCERT Campus  
Sri Aurobindo Marg  
New Delhi 110 016 Phone : 011-26562708

108, 100 Feet Road  
Hosdakere Halli Extension  
Banashankari III Stage  
Bengaluru 560 085 Phone : 080-26725740

Navjivan Trust Building  
P.O.Navjivan  
Ahmedabad 380 014 Phone : 079-27541446

CWC Campus  
Opp. Dhankal Bus Stop  
Panihati  
Kolkata 700 114 Phone : 033-25530454

CWC Complex  
Maligaon  
Guwahati 781 021 Phone : 0361-2674869

**Publication Team**

Head, Publication Division : Anup Kumar Rajput

Chief Editor : Shveta Uppal

Chief Production Officer : Arun Chitkara

Chief Business Manager (In charge) : Amitabh Kumar

Assistant Editor : R.N. Bhardwaj

Production Assistant Officer : Om Prakash

**Cover and Layout**

Shweta Rao

**Cartography**

Narendra Kumar Saini  
and Cartographic Designs  
Agency, New Delhi



## FOREWORD

The National Curriculum Framework (NCF), 2005, recommends that children's life at school must be linked to their life outside the school. This principle marks a departure from the legacy of bookish learning which continues to shape our system and causes a gap between the school, home and community. The syllabi and textbooks developed on the basis of NCF signify an attempt to implement this basic idea. They also attempt to discourage rote learning and the maintenance of sharp boundaries between different subject areas. We hope these measures will take us significantly further in the direction of a child-centred system of education outlined in the National Policy on Education (1986).

The success of this effort depends on the steps that school principals and teachers will take to encourage children to reflect on their own learning and to pursue imaginative activities and questions. We must recognise that, given space, time and freedom, children generate new knowledge by engaging with the information passed on to them by adults. Treating the prescribed textbook as the sole basis of examination is one of the key reasons why other resources and sites of learning are ignored. Inculcating creativity and initiative is possible if we perceive and treat children as participants in learning, not as receivers of a fixed body of knowledge.

These aims imply considerable change in school routines and mode of functioning. Flexibility in the daily time-table is as necessary as rigour in implementing the annual calendar so that the required number of teaching days are actually devoted to teaching. The methods used for teaching and evaluation will also determine how effective this textbook proves for making children's life at school a happy experience, rather than a source of stress or boredom. Syllabus designers have tried to address the problem of curricular burden by restructuring and reorienting knowledge at different stages with greater consideration for child psychology and the time available for teaching. The textbook attempts to enhance this endeavour by giving higher priority and space to opportunities for contemplation and wondering, discussion in small groups, and activities requiring hands-on experience.

The National Council of Educational Research and Training (NCERT) appreciates the hard work done by the textbook development committee

responsible for this book. We wish to thank the Chairperson of the advisory committee for textbooks in Social Sciences, at the higher secondary level, Professor Hari Vasudevan and the Chief Advisor for this book, Professor M.H. Qureshi for guiding the work of this committee. Several teachers contributed to the development of this textbook; we are grateful to their principals for making this possible. We are indebted to the institutions and organisations which have generously permitted us to draw upon their resources, material and personnel. We are especially grateful to the members of the National Monitoring Committee, appointed by the Department of Secondary and Higher Education, Ministry of Human Resource Development under the Chairpersonship of Professor Mrinal Miri and Professor G.P. Deshpande, for their valuable time and contribution. As an organisation committed to systemic reform and continuous improvement in the quality of its products, NCERT welcomes comments and suggestions which will enable us to undertake further revision and refinement.

New Delhi  
20 December 2005

*Director*  
National Council of Educational  
Research and Training

## RATIONALISATION OF CONTENT IN THE TEXTBOOKS

In view of the COVID-19 pandemic, it is imperative to reduce content load on students. The National Education Policy 2020, also emphasises reducing the content load and providing opportunities for experiential learning with creative mindset. In this background, NCERT has undertaken the exercise to rationalise the textbooks across all classes. Learning Outcomes already developed by the NCERT across classes have been taken into consideration in this exercise.

**Contents of the textbooks have been rationalised in view of the following:**

- Overlapping with similar content included in other subject areas in the same class
- Similar content included in the lower or higher class in same subject
- Difficulty level
- Content, which is easily accessible to students without much interventions from teachers and can be learned through children through self-learning or peer-learning
- Content, which is irrelevant in the present context

**This present edition, is a reformatted version after carrying out the changes given above.**



© NCERT  
not to be republished

## TEXTBOOK DEVELOPMENT COMMITTEE

### CHAIRPERSON, ADVISORY COMMITTEE FOR SOCIAL SCIENCE TEXTBOOKS AT HIGHER SECONDARY LEVEL

Hari Vasudevan, *Professor*, Department of History, University of Calcutta, Kolkata

### CHIEF ADVISOR

M. H. Qureshi, *Professor*, CSRD, Jawaharlal Nehru University, New Delhi

### MEMBERS

Rupa Das, *PGT*, DPS, R.K. Puram, New Delhi

S.M. Rashid, *Professor*, Department of Geography, Jamia Millia Islamia, New Delhi

Sucharita Sen, *Asstt. Professor*, CSRD, Jawaharlal Nehru University, New Delhi

Y. Sreekanth, *Lecturer*, DEME, NCERT, New Delhi

### MEMBER-COORDINATOR

Tannu Malik, *Lecturer*, DESSH, NCERT, New Delhi

**The following are applicable to all the maps of India used in this book**

© Government of India, Copyright 2006

1. The responsibility for the correctness of internal details rests with the publisher.
2. The territorial waters of India extend into the sea to a distance of twelve nautical miles measured from the appropriate base line.
3. The administrative headquarters of Chandigarh, Haryana and Punjab are at Chandigarh.
4. The interstate boundaries amongst Arunachal Pradesh, Assam and Meghalaya shown on this map are as interpreted from the "North-Eastern Areas (Reorganisation) Act.1971," but have yet to be verified.
5. The external boundaries and coastlines of India agree with the Record/Master Copy certified by Survey of India.
6. The state boundaries between Uttaranchal & Uttar Pradesh, Bihar & Jharkhand and Chhattisgarh & Madhya Pradesh have not been verified by the Governments concerned.
7. The spellings of names in this map, have been taken from various sources.



## ACKNOWLEDGEMENTS

The National Council of Educational Research and Training acknowledges the contribution of Milap Chand Sharma, *Reader*, CSRD, JNU; Muzammil Husain Quasmi, *Lecturer*, IASE, Jamia Millia Islamia; Aruna Gordan, *PGT*, St. Thomas School, New Delhi and C. Pargi, *PGT*, KV, Neemuch in the development of this textbook.

Acknowledgements are also due to Savita Sinha, *Professor and Head*, Department of Education in Social Science and Humanities for her valuable support at every stage of preparation of this textbook.

The Council is thankful to the Survey of India for certification of maps given in the textbook. It also gratefully acknowledges the support of individuals and organisations as listed below for providing various photographs and other materials used in the textbook-

Milap Chand Sharma, CSRD, JNU for photographs of gentle slope, steep slope, concave slope, convex slope, conical hill, plateau, V-shaped valley, U-shaped valley, gorge, spur, cliff, waterfall and rapids in Chapter 5; Narendra Kumar Saini, *Cartographer*, JMI for box 1.1, Figures 1.1 and 6.1; Concept Publishing Company (Book : Fundamentals of Cartography by R.P. Misra and A. Ramesh), New Delhi for Figures 1.4, 1.5 and 1.6 and NCERT textbook (Remote Sensing by Meenakshi) for Figures 6.3 and 6.6; Survey of India for Figures 1.2, 1.3 and parts of toposheet on page nos. 66 and 68; National Atlas and Thematic Mapping Organisation for Figures 1.7, 1.8, 1.9, 1.10, 1.11, 1.12 and 1.13; Regional Remote Sensing Service Centre, Jodhpur for Figures 6.4; National Remote Sensing Agency, Hyderabad for Figures 6.9, 6.11, 6.13, 6.14, 6.15, 6.16, 6.17 and image on page no. 91 and Digital Globe Agency for Figure 6.10.

The Council also gratefully acknowledges the contributions of Anil Sharma, *DTP Operator*; Sameer Khatana and Amar Kumar Prusty, *Copy Editors*; Shrestha and Deepti Sharma, *Proof Readers*; Dinesh Kumar, *Computer Station Incharge* who have helped in giving a final shape of this textbook. The efforts of Publication Department, NCERT are also duly acknowledged.

# THE CONSTITUTION OF INDIA

## PREAMBLE

**WE, THE PEOPLE OF INDIA**, having solemnly resolved to constitute India into a <sup>1</sup>**[SOVEREIGN SOCIALIST SECULAR DEMOCRATIC REPUBLIC]** and to secure to all its citizens :

**JUSTICE**, social, economic and political;

**LIBERTY** of thought, expression, belief, faith and worship;

**EQUALITY** of status and of opportunity and to promote among them all;

**FRATERNITY** assuring the dignity of the individual and the <sup>2</sup>[unity and integrity of the Nation];

**IN OUR CONSTITUENT ASSEMBLY** this twenty-sixth day of November, 1949 do **HEREBY ADOPT, ENACT AND GIVE TO OURSELVES THIS CONSTITUTION.**

1. Subs. by the Constitution (Forty-second Amendment) Act, 1976, Sec.2, for "Sovereign Democratic Republic" (w.e.f. 3.1.1977)
2. Subs. by the Constitution (Forty-second Amendment) Act, 1976, Sec.2, for "Unity of the Nation" (w.e.f. 3.1.1977)



## CONTENTS

FOREWORD	<i>iii</i>
RATIONALISATION OF CONTENT IN THE TEXTBOOKS	<i>v</i>
<b>CHAPTER 1</b> Introduction to Maps	1
<b>CHAPTER 2</b> Map Scale	17
<b>CHAPTER 3</b> Latitude, Longitude and Time	26
<b>CHAPTER 4</b> Map Projections	35
<b>CHAPTER 5</b> Topographical Maps	49
<b>CHAPTER 6</b> Introduction to Remote Sensing	69

# Constitution of India

## Part IV A (Article 51 A)

### Fundamental Duties

It shall be the duty of every citizen of India —

- (a) to abide by the Constitution and respect its ideals and institutions, the National Flag and the National Anthem;
- (b) to cherish and follow the noble ideals which inspired our national struggle for freedom;
- (c) to uphold and protect the sovereignty, unity and integrity of India;
- (d) to defend the country and render national service when called upon to do so;
- (e) to promote harmony and the spirit of common brotherhood amongst all the people of India transcending religious, linguistic and regional or sectional diversities; to renounce practices derogatory to the dignity of women;
- (f) to value and preserve the rich heritage of our composite culture;
- (g) to protect and improve the natural environment including forests, lakes, rivers, wildlife and to have compassion for living creatures;
- (h) to develop the scientific temper, humanism and the spirit of inquiry and reform;
- (i) to safeguard public property and to abjure violence;
- (j) to strive towards excellence in all spheres of individual and collective activity so that the nation constantly rises to higher levels of endeavour and achievement;
- \* (k) who is a parent or guardian, to provide opportunities for education to his child or, as the case may be, ward between the age of six and fourteen years.

**Note:** The Article 51A containing Fundamental Duties was inserted by the Constitution (42nd Amendment) Act, 1976 (with effect from 3 January 1977).

\* (k) was inserted by the Constitution (86th Amendment) Act, 2002 (with effect from 1 April 2010).

# Chapter 1

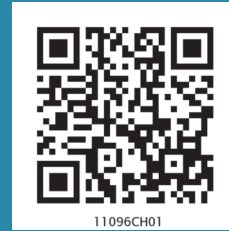

## Introduction to Maps



Figure 1.1 India as it is seen on the globe

You may be familiar with maps that you have seen in most of your books of social sciences representing the earth or any of its parts. You may also know that the shape of the earth is geoid (three-dimensional) and a globe can best represent it (Fig. 1.1). A map, on the other hand, is a simplified depiction of whole or part of the earth on a piece of paper. In other words, it is a two-dimensional form of the three-dimensional earth. Hence, a map can be drawn using a system of map projections (see

Chapter 4). As it is impossible to represent all features of the earth's surface in their true size and form, a map is drawn at a reduced scale. Imagine your school campus. If a plan/map of your school is to be drawn in its actual size, it will be as large as the campus itself. Hence, maps are drawn at a scale and projection so that each point on the paper corresponds to the actual ground position. Besides, the representation of different features is also simplified using symbols, colours and shades. A map is, therefore, defined as selective, symbolised and generalised representation of whole or a

2

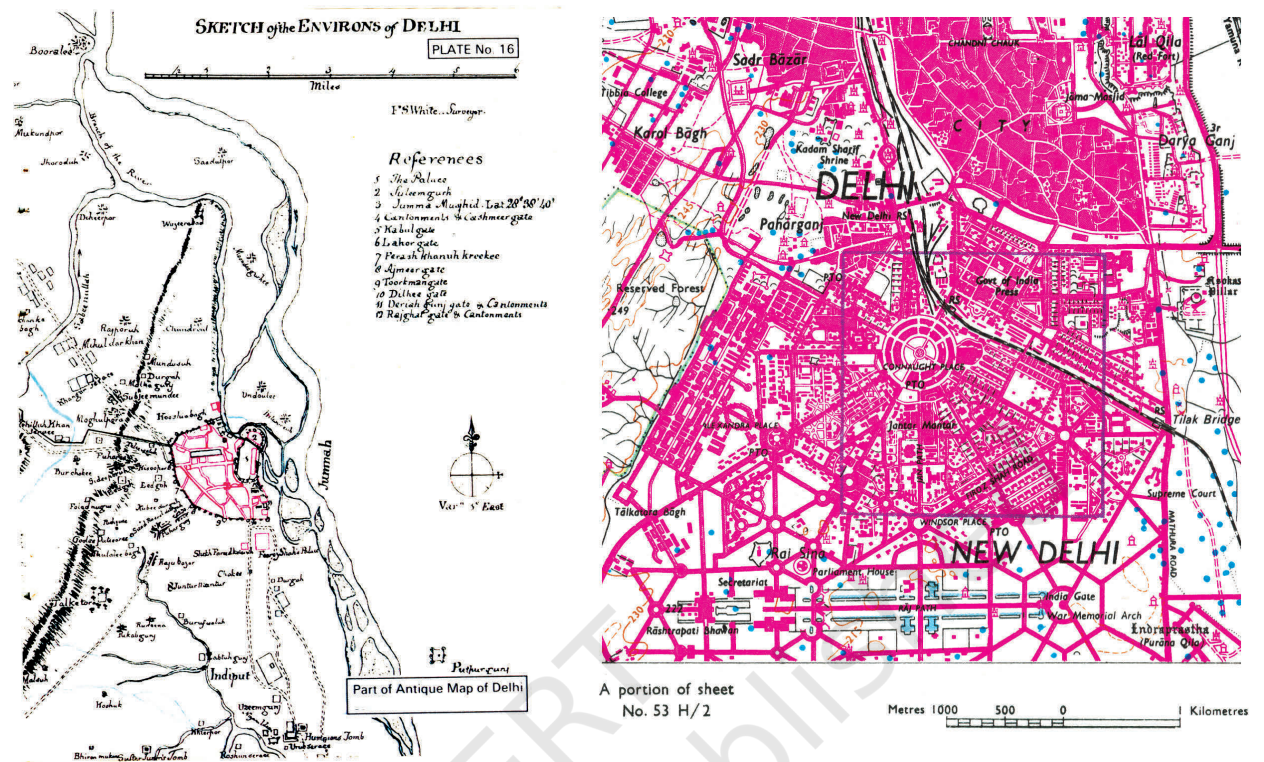

Figure 1.2 Sketch of the Environs of Delhi (Left) and a Map of Delhi (Right)

## Glossary

**Cadastral Map** : A large-scale map drawn at a scale of 1 : 500 to 1 : 4000 to show property boundaries, designating each parcel of land with a number.

**Cardinal Points** : North (N), South (S), East (E) and West (W).

**Cartography** : Art, science and technology of making maps, charts, plans and other modes of graphical expression as well as their study and use.

**Generalisation-Map** : A simplified representation of the features on the map, appropriate to its scale or purpose, without affecting their visual form.

**Geoid** : An oblate spheroid whose shape resembles the actual shape of the Earth.

**Map** : A selective, symbolised and generalised representation of the whole or part of the earth at a reduced scale.

**Map series** : A group of maps produced at same scale, style and specifications for a country or a region.

**Projection-Map** : The system of the transformation of the spherical surface onto a plane surface.

**Scale** : The ratio between the distances of two points on the map, plan or photograph and the actual distance between the same two points on the ground.

**Sketch Map** : A simplified map drawn freehand which fails to preserve the true scale or orientation.

part of the earth's surface on a plane surface at a reduced scale. It may also be understood that a simple network of lines and polygons without a scale shall not be called a map. It is only referred to as “the sketch” (Fig. 1.2). In the present chapter, we will study the essential requirements of maps, their types and the uses.

## ESSENTIALS OF MAP MAKING

In view of the variety of maps, we may find it difficult to summarise what they all have in common. Cartography, being an art and science of map-making, does include a series of processes that are common to all the maps. These processes that may also be referred to as essentials of maps are :

- ◇ Scale
- ◇ Map Projection
- ◇ Map Generalisation
- ◇ Map Design
- ◇ Map Construction and Production

**Scale:** We know that all maps are reductions. The first decision that a map-maker has to take is about the scale of the map. The choice of scale is of utmost importance. The scale of a map sets limits of information contents and the degree of reality with which it can be delineated on the map. For example, figure 1.3 provides a comparison between maps having different scales and the improvements made thereupon with the change in scale.

**Projection:** We also know that maps are a simplified representation of the three-dimensional surface of the earth on a plane sheet of paper. The transformation of all-side-curved-geoidal surface into a plane surface is another important aspect of the cartographic process. We should know that such a radical transformation introduces some unavoidable changes in directions, distances, areas and shapes from the way they appear on a geoid. A system of transformation of the spherical surface to the plane surface is called a map projection. Hence, the choice, utilisation and construction of projections is of prime importance in map-making.



A portion of sheet  
N. H.-43

Kilometres 10 5 0 10 20 30 Kilometres

A Portion of Sheet NH 43

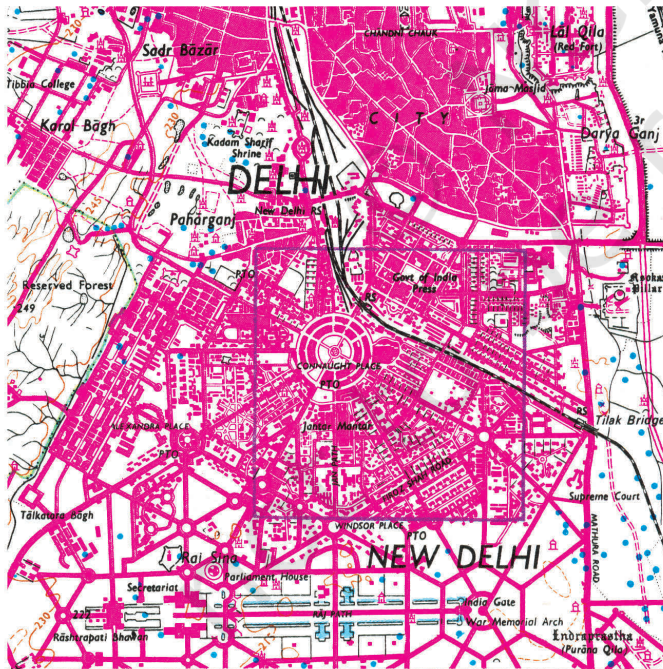

A portion of sheet  
No. 53 H/2

Metres 1000 500 0 Kilometres

A Portion of Sheet 53 H/2

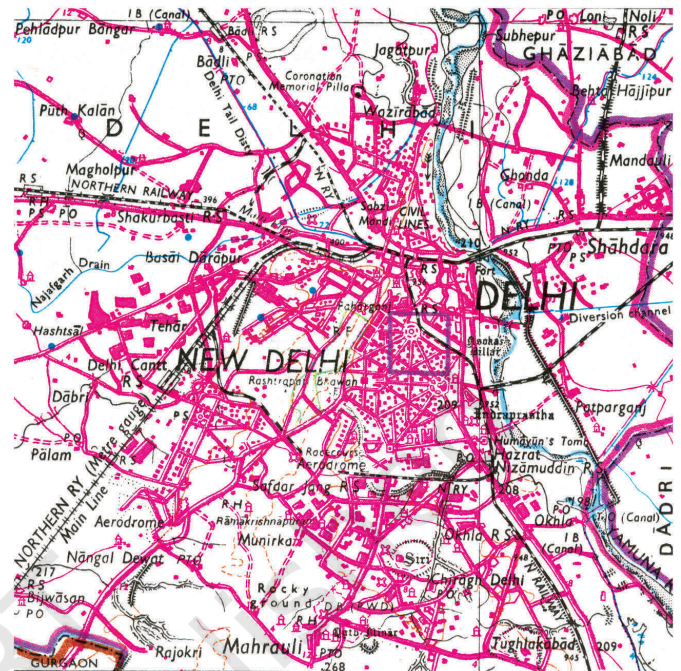

A portion of sheet  
No. 53 H

Kilometres 5 0 5 Kilometres

A Portion of Sheet 53 H

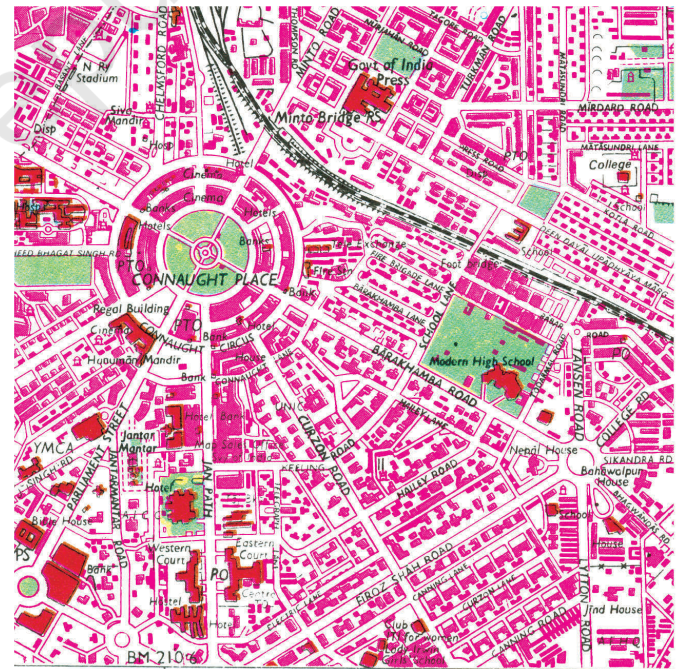

A portion of Delhi  
Guide Map

0 500 1000 Metres

A Portion of Guide Map

Figure 1.3 Effect of Scale on Mapped Information



**Generalisation:** Every map is drawn with a definite objective. For example, a general purpose map is drawn to show information of a general nature such as relief, drainage, vegetation, settlements, means of transportation, etc. Similarly, a special purpose map exhibits information pertaining to one or more selected themes like population density, soil types or location of industries. It is, therefore, necessary to carefully plan the map contents while the purpose of the map must be kept in the forefront. As maps are drawn at a reduced scale to serve a definite purpose, the third task of a cartographer is to generalise the map contents. In doing so, a cartographer must select the information (data) relevant to the selected theme and simplify it as per the needs.

**Map Design:** The fourth important task of a cartographer is the map design. It involves the planning of graphic characteristics of maps including the selection of appropriate symbols, their size and form, style of lettering, specifying the width of lines, selection of colours and shades, arrangement of various elements of map design within a map and design for map legend. The map design is, therefore, a complex aspect of map-making and requires thorough understanding of the principles that govern the effectiveness of graphic communication.

**Map Construction and Production:** The drawing of maps and their reproduction is the fifth major task in the cartographic process. In earlier times, much of the map construction and reproduction work used to be carried out manually. Maps were drawn with pen and ink and printed mechanically. However, the map construction and reproduction has been revolutionalised with the addition of computer assisted mapping and photo-printing techniques in the recent past.

## HISTORY OF MAP MAKING

The history of map making is as old as the history of mankind itself. The oldest map was found in Mesopotamia drawn on a clay tablet that belongs to 2,500 B.C. Figure 1.4 shows Ptolemy's Map of the World. Greek and the Arab geographers laid the foundation of modern cartography. The measurement of the circumference of the Earth and the use of the system of geographical coordinates in map-making are some of the significant contributions of the Greeks and the Arabs. The art and science of map

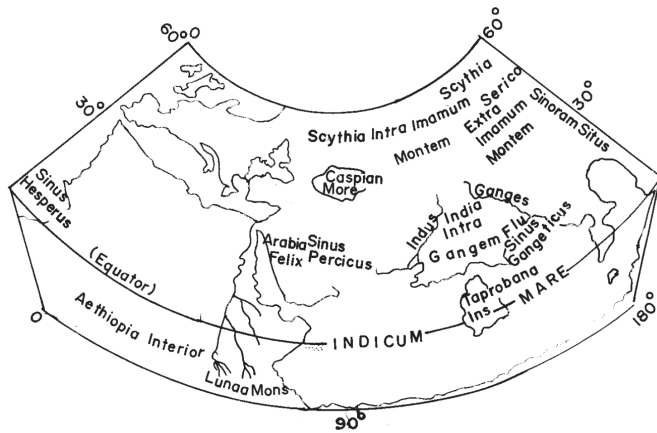

Figure 1.4 Ptolemy's Map of the World

making was revitalised in early modern period, with extensive efforts made to minimise the effects of the transformation of the geoid onto a plane surface. The maps were drawn on different projections to obtain true directions, correct distances and to measure area accurately. The aerial photography supplemented the ground method of survey and the uses of aerial photographs stimulated map-making in the nineteenth and twentieth centuries.

The foundation of map-making in India was laid during the Vedic period when the expressions of astronomical truths and cosmological revelations were made. The expressions were crystallised into 'sidhantas' or laws in classical treaties of Arya Bhatta, Varahamihira and Bhaskara, and others. Ancient Indian scholars divided the known world into seven 'dwipas' (Fig. 1.5). Mahabharata conceived a round world surrounded by water (Fig. 1.6).



Figure 1.5 Seven Dwipas of the World as conceived in Ancient India

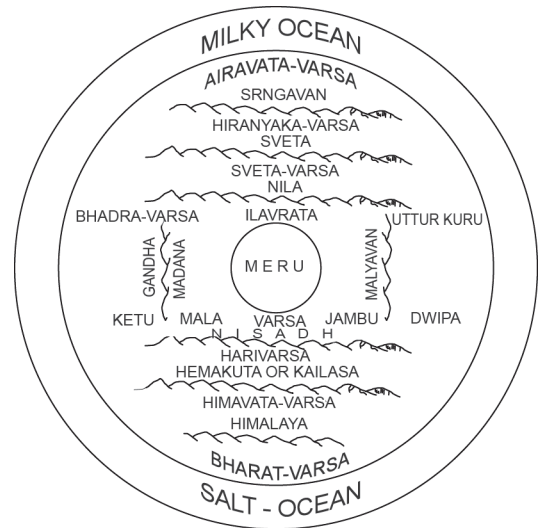

Figure 1.6 Round World surrounded by water as conceived in Mahabharata

Todarmal pioneered land surveying and map-making as an integral part of the revenue collection procedure. Besides, Sher Shah Suri's revenue maps further enriched the mapping techniques during the medieval period. The intensive topographical surveys for the preparation of up-to-date maps of the entire country, were taken up with the setting up of the Survey of India in 1767, which culminated with the map of Hindustan in 1785. Today, the Survey of India produces maps at different scales for the entire country.

**Types of Maps Based on Scale:** On the basis of scale, maps may be classified into large-scale and small-scale. Large scale maps are drawn to show small areas at a relatively large-scale. For example, the topographical maps drawn at a scale of 1: 250,000, 1:50,000 or 1:25,000 and the village maps, the zonal plans of the cities and house plans prepared on a scale of 1:4,000, 1:2,000 and 1:500 are large scale maps. On the other hand, small-scale maps are drawn to show large areas. For example, atlas maps, wall maps, etc.

**(i) Large-scale Maps:** Large-scale maps are further divided into the following types :

(a) Cadastral maps

(b) Topographical maps

*(a) Cadastral Maps :* The term 'cadastral' is derived from the French word 'cadastre' meaning 'register of territorial property'. These maps are drawn to show the ownership of landed property by demarcating field boundaries of agricultural land and the plan of individual houses in urban areas. The cadastral maps are prepared by the government agencies to realise revenue and taxes, along with keeping a record of ownership. These maps are drawn on a very large scale, such as the cadastral maps of villages at 1 : 4,000 scale and the city plans at a scale of 1 : 2,000 and larger.

*(b) Topographical Maps :* These maps are also prepared on a fairly large scale. The topographical maps are based on precise surveys and are prepared in the form of series of maps made by the national mapping agencies of almost all countries of the world (Chapter 5). For example, the Survey of India undertakes the topographical mapping of the entire country at 1 : 250,000, 1 : 50,000 and 1 : 25,000 scale (Fig. 1.3). These maps follow uniform colours and symbols to show topographic details such as relief, drainage, agricultural land, forest, settlements, means of

communication, location of schools, post offices and other services and facilities.

**(ii) Small-scale Maps:** Small-scale maps are further divided into the following types :

- (a) Wall Maps
- (b) Atlas Maps

*(a) Wall Maps :* These maps are generally drawn on large size paper or on plastic base for use in classrooms or lecture halls. The scale of wall maps is generally smaller than the scale of topographical maps but larger than atlas maps.

*(b) Atlas Maps :* Atlas maps are very small-scale maps. These maps represent fairly large areas and present highly generalised picture of the physical or cultural features. Even so, an atlas map serves as a graphic encyclopaedia of the geographical information about the world, continents, countries or regions. When consulted properly, these maps provide a wealth of generalised information regarding location, relief, drainage, climate, vegetation, distribution of cities and towns, population, location of industries, transport-network system, tourism and heritage sites, etc.

**Types of Maps Based on Function:** The maps may also be classified on the basis of their functions. For example, a political map serves the function of providing administrative divisions of a continent or a country and a soil map shows the distribution of different types of soils. Broadly, maps based on their functions may be classified into physical maps and cultural maps.

**(i) Physical Maps:** Physical maps show natural features such as relief, geology, soils, drainage, elements of weather, climate and vegetation, etc.

*(a) Relief Maps:* Relief maps show general topography of an area like mountains and valleys, plains, plateaus and drainage. Figure 1.7 shows the relief and slope map of Nagpur district.

*(b) Geological Maps:* These maps are drawn to show geological structures, rock types, etc. Figure 1.8 shows the distribution of rocks and minerals in Nagpur district.

*(c) Climatic Maps :* These maps depict climatic regions of an area. Besides, maps are also drawn to show the distribution of temperature,

## RELIEF AND SLOPE

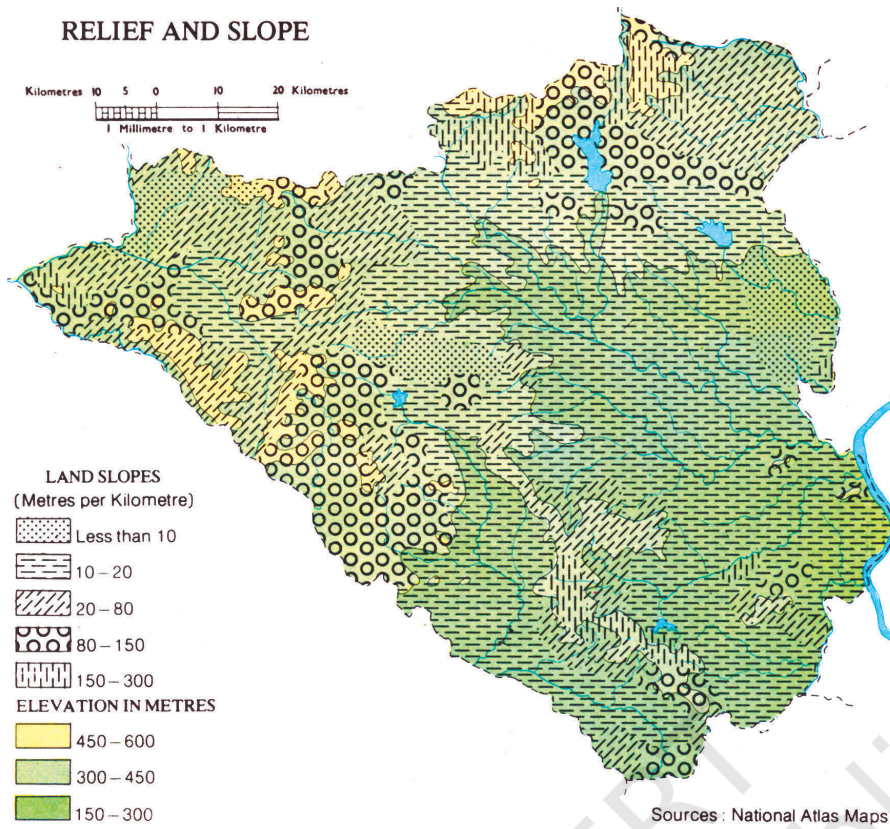

Figure 1.7 Relief and Slope Map of Nagpur District

## ROCKS AND MINERALS

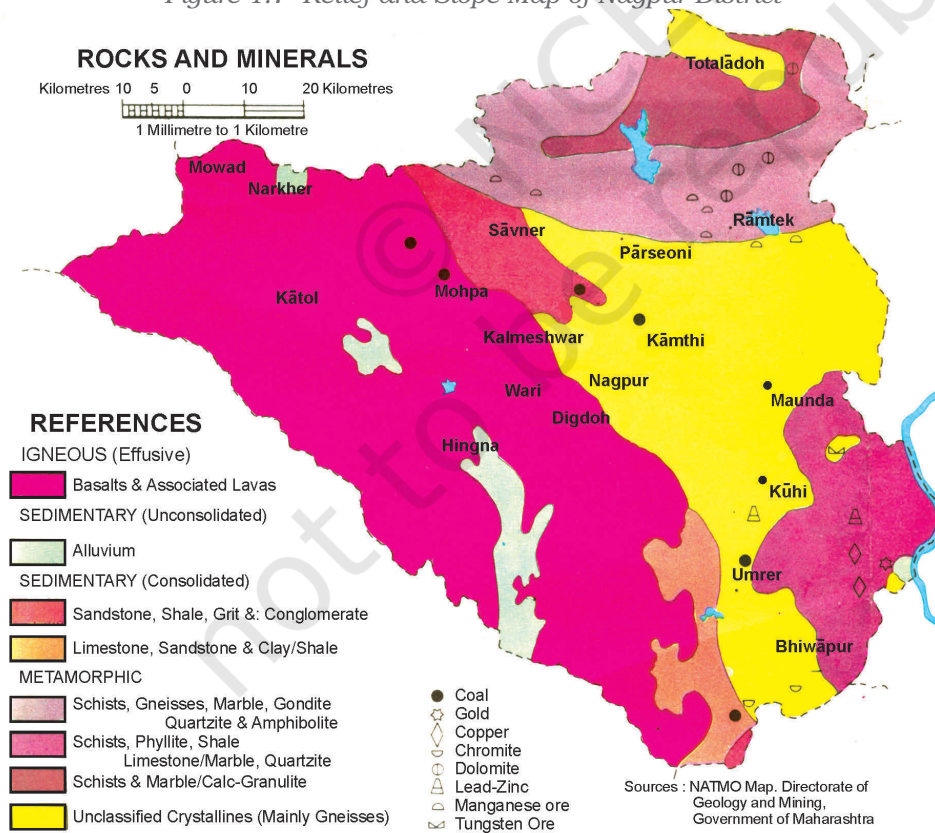

Figure 1.8 Distribution of Rocks and Minerals in Nagpur District

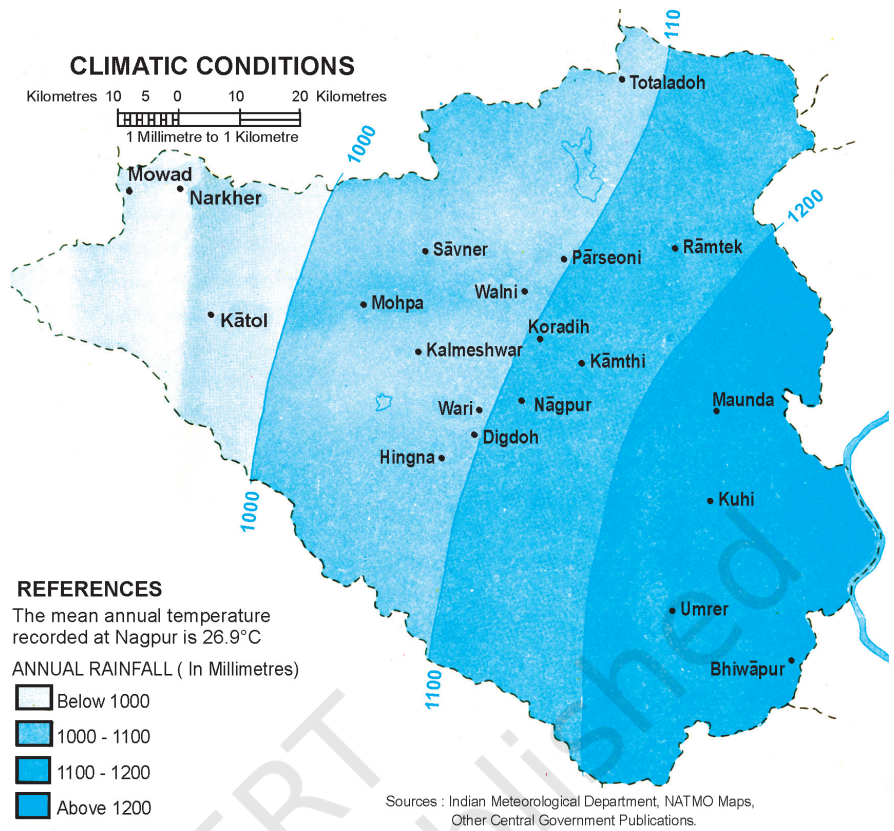

Figure 1.9 Map showing Climatic Conditions of Nagpur District

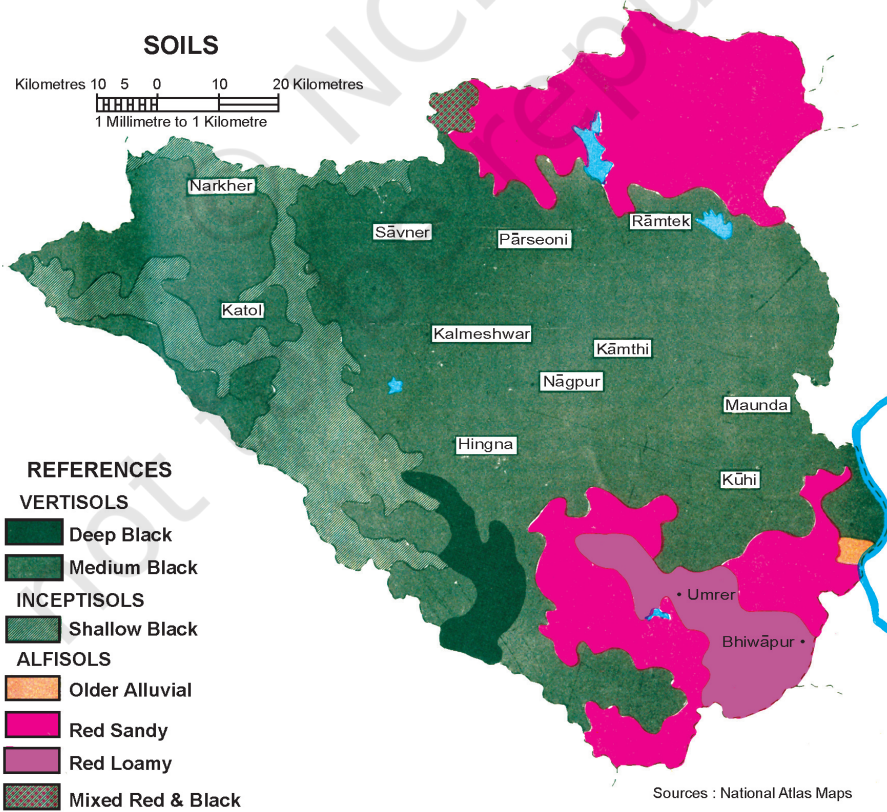

Figure 1.10 Soils of Nagpur District

rainfall, cloudiness, relative humidity, direction and velocity of winds and other elements of weather (Fig 1.9).

(d) *Soil Maps* : Maps are also drawn to show the distribution of different types of soil(s) and their properties (Fig. 1.10).

**(ii) Cultural Maps:** Cultural maps show man-made features. These include a variety of maps showing population distribution and growth, sex and age, social and religious composition, literacy, levels of educational attainment, occupational structure, location of settlements, facilities and services, transportation lines and production, distribution and flow of different commodities.

(a) *Political Maps* : These maps show the administrative divisions of an area such as country, state or district. These maps facilitate the administrative machinery in planning and management of the concerned administrative unit.

(b) *Population Maps*: The population maps are drawn to show the distribution, density and growth of population, age and sex composition,

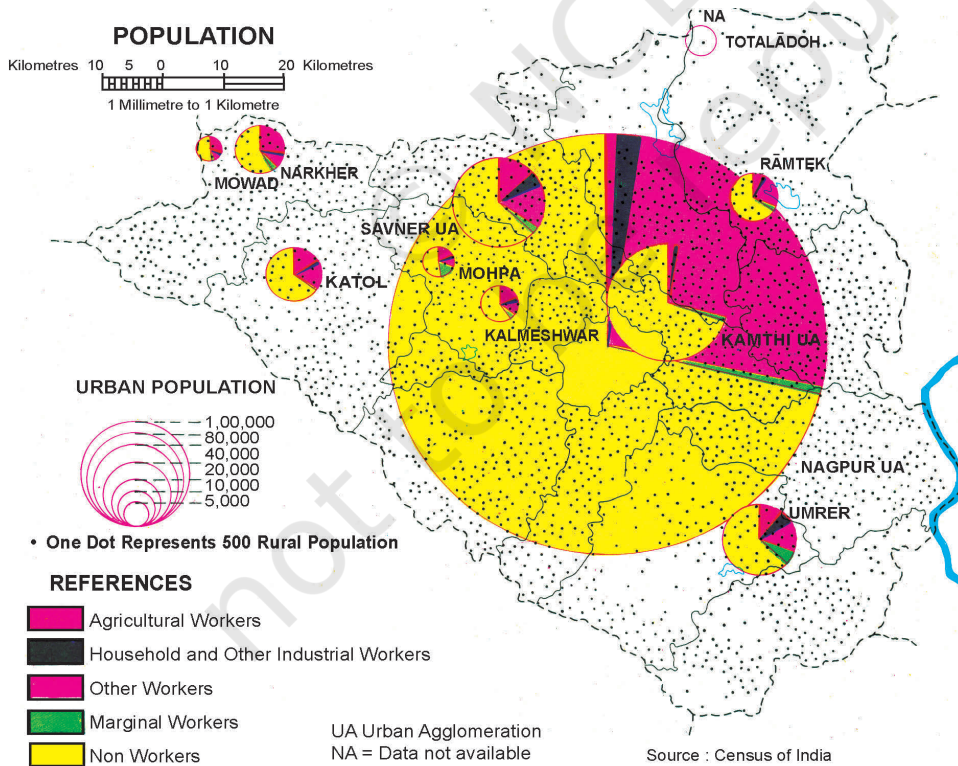

Figure 1.11 Nagpur District : Distribution of Population

distribution of religious, linguistic and social groups, occupational structure of the population, etc. (Fig 1.11 on previous page). Population maps serve the most significant role in the planning and development of an area.

(c) *Economic Maps:* Economic maps depict production and distribution of different types of crops and minerals, location of industries and markets, routes for trade and flow of commodities. Figures 1.12 and 1.13 show the land use and cropping patterns and the location of industries in Nagpur district respectively.

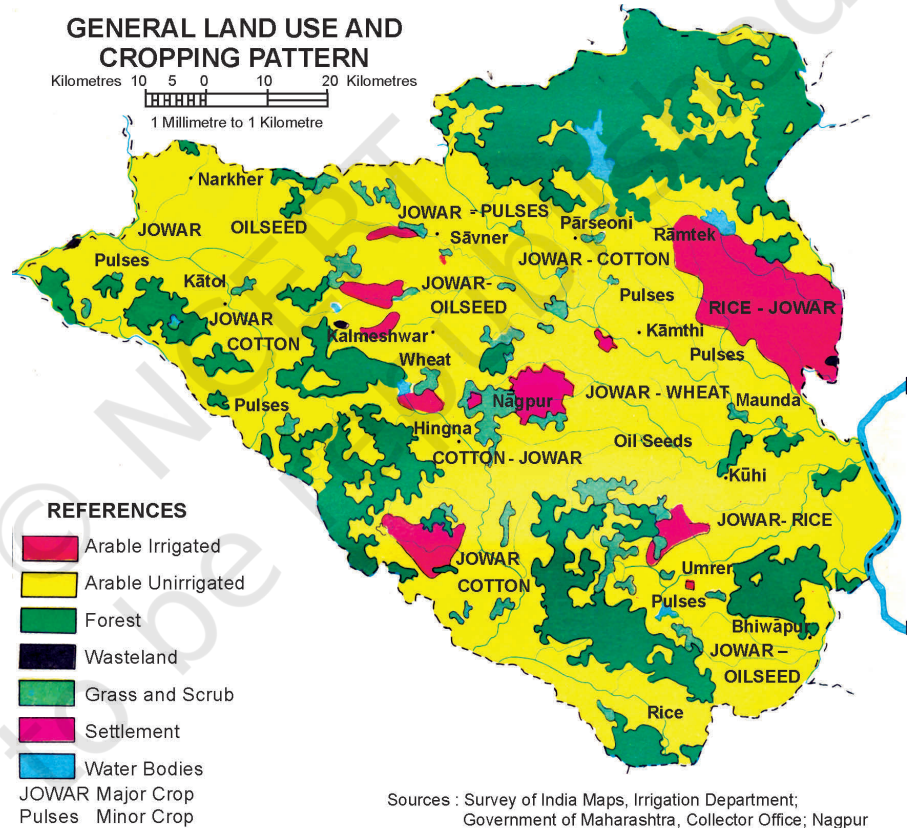

Figure 1.12 Land use and Cropping Patterns in Nagpur District

(d) *Transportation Maps:* These maps show roads, railway lines and the location of railway stations and airports.





Figure 1.13 Location of Industries in Nagpur District

## USES OF MAPS

Geographers, planners and other resource scientists use maps. In doing so, they make various types of measurements to determine distances, directions and area.

**Measurement of Distance:** The linear features shown on the maps fall into two broad categories, i.e. straight lines and erratic or zigzag lines. The measurement of straight line features like roads, railway lines and canals is simple. It can be taken directly with a pair of dividers or a scale placed on the map surface. However, distances are required, more often, along erratic paths, i.e. the coastlines, rivers and streams. The distances along all such features can be measured by placing a thread at the starting point and carrying it along the line up to the end point. The thread is then stretched and measured to determine the distance. It can also be measured by using a simple instrument called *Rotameter*.

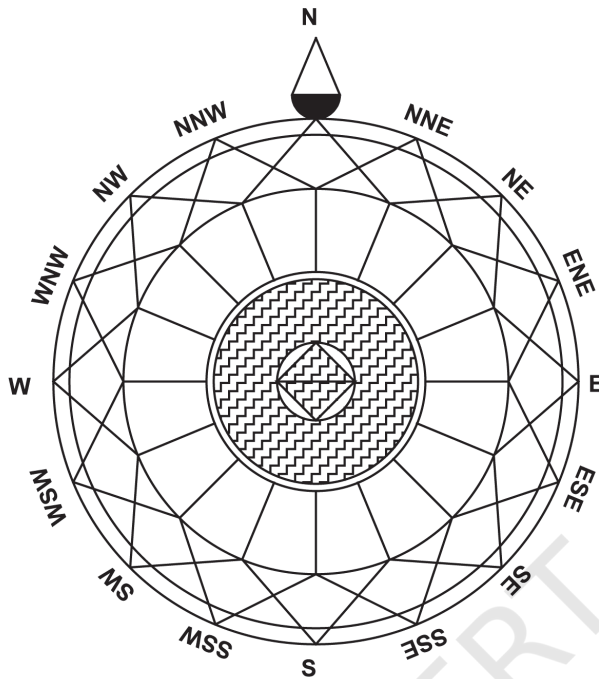

Figure 1.14 Cardinal and Intermediate Directions

The wheel of the 'rotameter' is moved along the route to measure the distance.

### **Measurement of Direction:**

Direction is defined as an imaginary straight line on the map showing the angular position to a common base direction. The line pointing to the north is zero direction or the base direction line. A map always shows the north direction. All other directions are determined in to this relation. The north direction enables the map-user to locate different features with respect to each other. The four commonly known directions are North, South, East and West. These are also called the cardinal points. In between the cardinal points, one may have several intermediate directions (Fig. 1.14).

**Measurement of Area:** The measurement of area of features like that of administrative and geographic units is also carried out over the surface of the map by map-users. There are different methods in which areas can be determined. One of the simplest but not very accurate method to determine the area is by means of regular pattern of squares. In this method, the area to be measured is covered by squares by placing a sheet of graph paper beneath the map on an illuminated tracing table or by tracing the area onto the square sheet. The total number of 'whole squares' are summed up, together with 'partial squares'. The area is then determined by a simple equation :

$$\text{Area} = \text{Sum of whole squares} + \left( \frac{\text{Sum of partial squares}}{2} \right) \times \text{Map Scale}$$

The area can also be calculated by using a fixed area *polar planimeter* (Box 1.1).

### Box 1.1 Measurement of Area using Polar Planimeter

The area calculation is also carried out using Polar Planimeter. In this instrument, a measure is made of the movement of a rod whose locus is constrained by having one end fixed to a radial arc. The area to be measured is traced along its perimeter in a clockwise direction with an index mark, starting from one convenient point to which the index of the tracing arm must exactly return.

Reading on the dial, before and after the tracing of area's perimeter, will give a value in instrumental units. These readings are multiplied by the same constant for the particular instrument to convert into areas in square inches or centimetres.



You may explore more on [bhuvan.nrsc.gov.in](http://bhuvan.nrsc.gov.in)

### EXERCISE

1. Choose the right answer from the four alternatives given below:
  - i) Which one of the following is essential for the network of lines and polygons to be called a map ?
    - (a) Map Legend
    - (b) Symbols
    - (c) North Direction
    - (d) Map Scale
  - ii) A map bearing a scale of 1 : 4000 and larger is called :
    - (a) Cadastral map
    - (b) Topographical map
    - (c) Wall map
    - (d) Atlas map
  - iii) Which one of the following is NOT an essential element of maps ?
    - (a) Map Projection
    - (b) Map Generalisation
    - (c) Map Design
    - (d) History of Maps

2. Answer the following questions in about 30 words:

- (i) What is map generalisation ?
- (ii) Why is map design important ?
- (iii) What are different types of small-scale maps ?
- (iv) List out two major types of large-scale maps ?
- (v) How is a map different from a sketch ?

3. Write an explanatory account of types of maps.



© NCERT  
not to be republished

## Chapter 2



# Map Scale

You have read in Chapter 1 that the scale is an essential element of all types of maps. It is so important that if a network of lines and polygons does not carry a scale, we call it a “sketch”. Why is the scale so important ? What does it mean ? What are the different methods of showing the scale on a map? How useful is the scale in measuring the distances and the area? These are some of the questions which will be taken up in the present chapter.

### Glossary

**Denominator:** The number below the line in a fraction. For example, in a fraction of 1 : 50,000, 50,000 is the denominator.

**Numerator:** The number above the line in a fraction. For example, in a fraction of 1 : 50,000, 1 is the numerator.

**Representative Fraction:** A method of scale of a map or plan expressed as a fraction showing the ratio between a unit distance on the map or plan, and the distance measured in the same units on the ground.

### What is Scale ?

You must have seen maps with a scale bar indicating equal divisions, each marked with readings in kilometres or miles. These divisions are used to find out the ground distance on the map. In other words, a map scale provides the relationship between the map and the whole or a part of the earth’s surface shown on it. We can also express this relationship as a ratio of distances between two points on the map and the corresponding distance between the same two points on the ground.

There are at least three ways in which this relationship can be expressed. These are:

1. Statement of Scale
2. Representative Fraction (R. F.)
3. Graphical Scale

Each of these methods of scale has advantages and limitations. But before taking up these issues, let us understand that the scale is normally expressed in one or the other system of measurement. You must have read and/or used kilometre, metre, centimetre etc. to measure the linear distances between two points on the ground. You might have also heard of miles, furlongs, yards, feet, etc. These are two different systems of measurement of the distances used in different countries of the world. Whereas the former system is referred to as the Metric System of Measurement and presently used in India and many other countries of the world, the latter system is known as the English System of Measurement and is prevalent in both the United States and the United Kingdom. India also used this system for measuring/showing linear distances before 1957. The units of measurement of these systems are given in Box 2.1.

### METHODS OF SCALE

As mentioned above, the scale of the map may be expressed using one or a combination of more than one methods of scale. Let us see how these methods are used and what are their advantages and limitations.

#### Box 2.1 Systems of Measurements

##### Metric System of Measurement

1 km	=	1000 Metres
1 Metre	=	100 Centimetres
1 Centimetre	=	10 Millimetres

##### English System of Measurement

1 Mile	=	8 Furlongs
1 Furlong	=	220 Yards
1 Yard	=	3 feet
1 Foot	=	12 Inches

**1. Statement of Scale:** The scale of a map may be indicated in the form of a written statement. For example, if on a map a written statement appears stating 1 cm represents 10 km, it means that on that map a distance of 1 cm is representing 10 km of the corresponding ground distance. It may also be expressed in any other system of measurement, i.e. 1 inch represents 10 miles. It is the simplest of the three methods. However, it may be noted that the people who are familiar with one system may not understand the statement of scale given in another system of measurement. Another limitation of this method is that if the map is reduced or enlarged, the scale will become redundant and a new scale is to be worked out.

**2. Graphical or Bar Scale:** The second type of scale shows map distances and the corresponding ground distances using a line bar with primary and secondary divisions marked on it. This is referred to as the graphical scale or bar scale (Fig. 2.1). It may be noted that the scale readings as shown on the bar scale in Figure 2.1 reads only in kilometres and metres. In yet another bar scale the readings may be shown in miles and furlongs. Hence, like the statement of scale method, this method also finds restricted use for only those who can understand it. However, unlike the statement of the scale method, the graphical scale stands valid even when the map is reduced or enlarged. This is the unique advantage of the graphical method of the map scale.

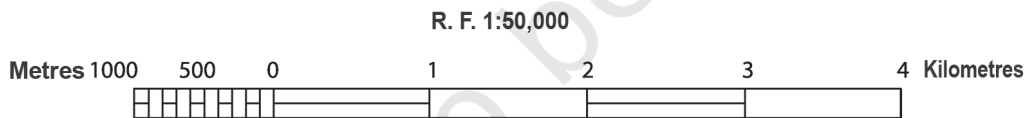

Figure 2.1

**3. Representative Fraction ( R. F. ):** The third type of scale is R. F. It shows the relationship between the map distance and the corresponding ground distance in units of length. The use of units to express the scale makes it the most versatile method.

R. F. is generally shown in fraction because it shows how much the real world is reduced to fit on the map. For example, a fraction of 1 : 24,000 shows that one unit of length on the map represents 24,000 of the same units on the ground i.e. one mm, one cm or one inch

on the map representing 24,000 mm, 24,000 cm and 24,000 inches, respectively of the ground. It may, however, be noted that while converting the fraction of units into Metric or English systems, units in centimetre or inch are normally used by convention. This quality of expressing scale in units in R. F. makes it a universally acceptable and usable method. Let us take R. F. of 1 : 36,000 to elaborate the universal nature of R. F.

If the given scale is 1: 36,000, a person acquainted with the Metric System will read the given units by converting them into cm, i.e. the distance of 1 unit on the map as 1 cm and the distance of 36,000 units on the ground distance as 36,000 cm. These values may subsequently be converted into a statement of scale, i.e. 1 cm represents 360 metres. (by dividing values in denominator by the number of centimetres in a metre, i.e. 100). Yet another user of the map familiar with the English system of measurement will understand the map scale by converting it into a statement of scale convenient to him/her and read the map scale as 1 inch represents 1,000 yards. The said statement of scale will be obtained by dividing 36,000 units in the denominator by 36 (number of inches in a yard).

### CONVERSION OF SCALE

If you have carefully read the advantages and limitations of the different methods of scale, then it will not be difficult for you to convert the Statement of Scale into Representative Fraction and vice-versa.

#### Statement of Scale into R. F.

**Problem** Convert the given Statement of Scale of 1 inch represents 4 miles into R. F.

**Solution** The given Statement of Scale may be converted into R. F. using the following steps.

1 inch represents 4 miles

or 1 inch represents  $4 \times 63,360$  inches (1 mile = 63,360 inches)

or 1 inch represents 253,440 inches

**NOTE :** We can now replace the character “inches” into “units” and read it as :

1 unit represents 253,440 Units

**Answer** **R. F. 1 : 253, 440**



### **R. F. into Statement of Scale**

**Problem** Convert R. F. 1 : 253, 440 into Statement of Scale (In Metric System)

**Solution** The given R. F. of 1 : 253, 440 may be converted into Statement of Scale using the following steps :

1 : 253, 440 means that  
1 unit on the map represents 253, 440 units on the ground.

or 1 cm represents 253, 440/100,000 (1 km = 100,000 cm)

or 1 cm represents 2.5344 km

After rounding of up to 2 decimals, the answer will be :

**Answer** **1 cm represents 2.53 km**

### **Construction of the Graphical/Bar Scale**

**Problem 1** Construct a graphical scale for a map drawn at a scale of 1 : 50,000 and read the distances in kilometre and metre.

**NOTE:** By convention, a length of nearly 15 cm is taken to draw a graphical scale.

**Calculations** To get the length of line for the graphical scale, these steps may be followed:

1 : 50,000 means that  
1 unit of the map represents 50,000 units on the ground

or 1 cm represents 50,000 cm

or 15 cm represents  $50,000 \times 15/100,000$  km

or 15 cm represents 7.5 km

Since the value of 7.5 (km) is not a round number, we can choose 5 or 10 (km) as the round number. In the present case, we choose 5 as the round number.

To determine the length of the line to show 5 km, the following calculations are to be carried out:

7.5 km is represented by a line of 15 cm  
5 km will be represented by a line of  $15 \times 5/7.5$

or 5 km will be represented by a line of 10 cm

**Construction** The graphical scale may be constructed by following these steps:

Draw a straight line of 10 cm and divide it into 5 equal parts and assign a value of 1 km each for 4 right side divisions from the 0 mark. Also

divide the extreme left side division into 10 equal parts and mark each division by a value of 100 metres, beginning from 0. (You may also divide it into 2, 4, or 5 parts and assign a value of 500, 250, or 200 metres to

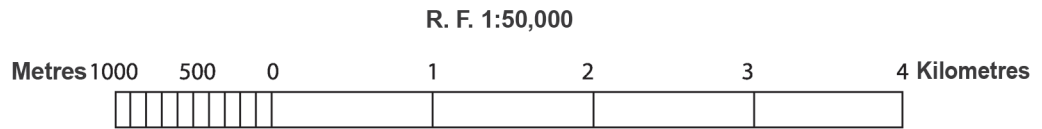

each of the subdivisions respectively from 0.

Figure 2.2

**Problem 2** Construct a graphical scale when the given Statement of Scale is 1 inch representing 1 mile and read the distances in miles and furlongs.

**NOTE:** By convention, a length of nearly 6 inches is taken to draw a graphical scale.

**Calculations** To get the length of line for the graphical scale, these steps may be followed:

- 1 inch represents 1 mile
- or 6 inches represents 6 miles

**Construction** The graphical scale may be constructed in the following steps:

Draw a straight line of 6 inches and divide it into 6 equal parts and assign a value of 1 mile each for 5 right side divisions. Also divide the extreme left side division into 4 equal parts and mark each division by a value of 2 miles each, beginning from 0.

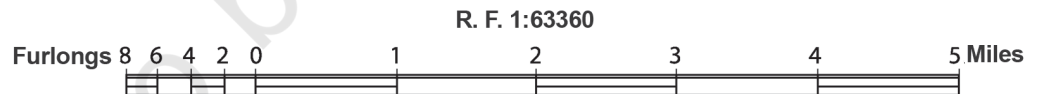

Figure 2.3

**Problem 3** Construct a graphical scale when the given R. F. is 1 : 50,000 and read the distances in miles and furlongs.

**Calculations** To get the length of the line for the graphical scale, these steps may be followed:

- 1 : 50,000 means that
- 1 unit represents 50,000 units
- or 1 inch represents 50,000 inches.
- or 6" represents  $50,000 \times 6/63,360$  miles
- = 6' represents 4.73 miles

Since a figure of 4.73 (miles) is not a round number, we take 5 as the round number.

To determine the length of the line to show 5 km, the following calculations are to be carried out :

$$\begin{aligned} & 4.73 \text{ miles are represented by a line of 6 inches} \\ & 5 \text{ miles will be represented by a line of } 6 \times 5/4.73 \\ = & 5 \text{ miles will be represented by a line of 6.34 inches} \end{aligned}$$

**Construction** The graphical scale may be constructed in the following steps:

To construct a graphical scale to show 5 miles we need to draw a line of 6.34 inches and divide it into 5 equal parts. The question is how can an unequal line of 6.3 inches be divided into 5 equal parts. To do so we can use the following procedure:

- ◇ Draw a straight line of 6.3 inches.
- ◇ Draw lines at an angle of 40° or 45° from the start and end nodes of the lines and divide them into 5 equal parts of 1 or 1.5 inches each.
- ◇ Draw dotted lines joining the divisions marked on the two lines.
- ◇ Mark the intersections of these lines at the primary scale.

By doing so, you will divide the unequal line of 6.3 inches into 5 equal parts. You can repeat the same way to divide the extreme left part on the primary scale into 4 or 8 parts to show the number of furlongs that are equivalent to 1 mile.

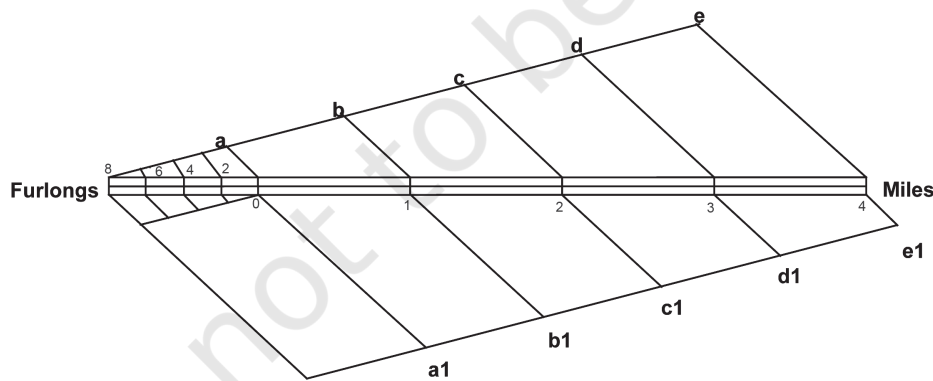

Figure 2.4 Drawing of equal divisions in a graphical scale

**EXERCISE**

1. Choose the right answer from the four alternatives given below:
  - (i) Which one of the following methods of scale is a universal method?
    - (a) Simple Statement
    - (b) Representative Fraction
    - (c) Graphical Scale
    - (d) None of the above
  - (ii) Map distance in a scale is also known as:
    - (a) Numerator
    - (b) Denominator
    - (c) Statement of Scale
    - (d) Representative Fraction
  - (iii) 'Numerator' in scale represents:
    - (a) Ground distance
    - (b) Map distance
    - (c) Both the distances
    - (d) None of the above
  
2. Answer the following questions in about 30 words:
  - (i) What are the two different systems of measurement?
  - (ii) Give one example each of statement of scale in Metric and English system.
  - (iii) Why is the Representative Fraction method called a Universal method?
  - (iv) What are the major advantages of the graphical method?
  
3. Convert the given Statement of Scale into Representative Fraction (R. F.).
  - (i) 5 cm represents 10 km
  - (ii) 2 inches represents 4 miles
  - (iii) 1 inch represents 1 yard
  - (iv) 1 cm represents 100 metres
  
4. Convert the given Representative Fraction (R. F.) into Statement of Scale in the System of Measurement shown in parentheses:
  - (i) 1 : 100,000 (into km)
  - (ii) 1 : 31680 (into furlongs)

*Map Scale*

(iii) 1 : 126,720 (into miles)

(iv) 1 : 50,000 (into metres)

5. Construct a graphical scale when the given R. F. is 1 : 50,000 and read the distances in kilometre and metre.



© NCERT  
not to be republished



# Latitude, Longitude and Time

THE EARTH is nearly a sphere. It is because of the fact that the equatorial radius and the polar radius of the earth is not the same. The rotation of the earth over its axis produces bulging at the equator. Hence, the actual shape resembles that of an oblate spheroid. The shape of the earth presents some difficulties in positioning its surface features, as there is no point of reference from which to measure the relative positions of other points. Hence, a network of imaginary lines is drawn on a globe or a map to locate various places. Let us find out what are these lines and how are they drawn.

The spinning of the earth on its axis from west to east provides two natural points of reference, i.e. North and South Poles. They form the basis for the *geographical grid*. A network of intersecting lines is drawn for the purpose of fixing the locations of different features. The grid consists of two sets of horizontal and vertical lines, which are called parallels of latitudes and the meridians of longitudes.

Horizontal lines are drawn parallel to each other in east-west direction. The line drawn midway between the North Pole and the South Pole is called the equator. It is the largest circle and divides the globe into two equal halves. It is also called a great circle. All the other parallels get smaller in size, in proportion to their distance from the equator towards the poles and divide the earth into two unequal halves, also referred to as the small circles. These imaginary lines running east-west are commonly known as the *parallels of latitude*.

The vertical lines running north-south, join the two poles. They are called the *meridians of longitude*. They are spaced farthest apart at the equator and converge at a point at each pole.

The latitudes and longitudes are commonly referred to as geographical coordinates as they provide systematic network of lines upon which the position of various surface features of the earth, can be represented. With the help of these coordinates, location, distance and direction of various points can be easily determined.

Although an infinite number of parallels and meridians may be drawn on a globe, only a selected number of them are usually drawn on a map. Latitudes and longitudes are measured in degrees ( $^{\circ}$ ) because they represent angular distances. Each degree is further divided into 60 minutes ( $'$ ) and each minute into 60 seconds ( $''$ ).

### Glossary

**Parallels of Latitude :** The parallels of latitude refer to the angular distance, in degrees, minutes and seconds of a point north or south of the Equator. Lines of latitude are often referred to as parallels.

**Meridians of Longitude :** The meridians of longitude refer to the angular distance, in degrees, minutes, and seconds, of a point east or west of the Prime (*Greenwich*) Meridian. Lines of longitude are often referred to as meridians.

### PARALLELS OF LATITUDES

The latitude of a place on the earth's surface is its distance north or south of the equator, measured along the meridian of that place as an angle from the centre of the earth. Lines joining places with the same latitudes are called *parallels*. The value of equator is  $0^{\circ}$  and the latitude of the poles are  $90^{\circ}\text{N}$  and  $90^{\circ}\text{S}$  (Fig. 3.1 on the next page). If parallels of latitude are drawn at an interval of one degree, there will be 89 parallels in the northern and the southern hemispheres each. The total number of parallels thus drawn, including the equator, will be 179. Depending upon the location of a feature or a place north or south of the equator, the letter N or S is written along with the value of the latitude.

If the earth were a perfect sphere, the length of  $1^{\circ}$  of latitude (a one degree arc of a meridian) would be a constant value, i.e. 111 km everywhere on the earth. This length is almost the same as that of a

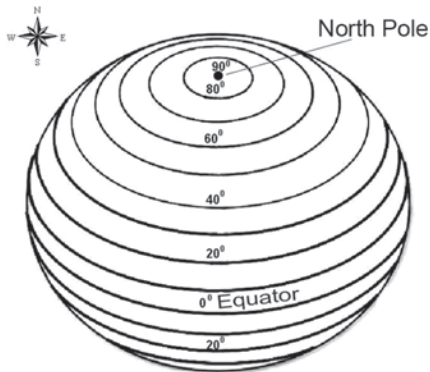

Figure 3.1 Parallels of Latitudes

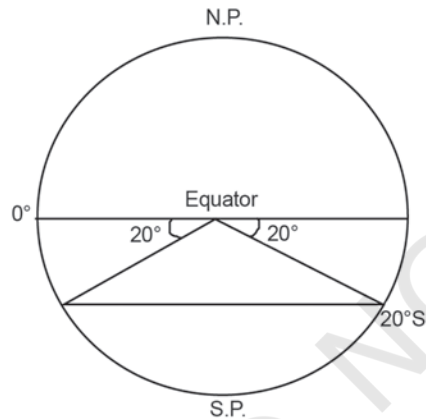

Figure 3.2 Drawing of Parallels of Latitudes

degree of longitude at the equator. But to be precise, a degree of latitude changes slightly in length from the equator to the poles. While at the equator, it is 110.6 km at the poles, it is 111.7 km. Latitude of a place may be determined with the help of the altitude of the sun or the Pole Star.

### DRAWING THE PARALLELS OF LATITUDES

How to draw the parallels of latitudes? Draw a circle and divide it into two equal halves by drawing a horizontal line in the centre. This represents the equator. Place a protractor on this circle in a way that  $0^\circ$  and  $180^\circ$  line on the protractor coincide with the equator on the paper. Now to draw  $20^\circ\text{S}$ , mark two points at an angle of  $20^\circ$  from the equator, east and west in the lower half of the circle, as shown in Fig. 3.2. The arms of the angle cut the circle at two points. Join these two points by a line parallel to the equator. It will be  $20^\circ\text{S}$ .

### MERIDIANS OF LONGITUDE

Unlike the parallels of latitude which are circles, the meridians of longitude are semi-circles that converge at the poles. If opposite meridians are taken together, they complete a circle, but, they are valued separately as two meridians.

The meridians intersect the equator at right angles. Unlike the parallels of latitude, they are all equal in length. For convenience of numbering, the meridian of longitude passing through the Greenwich observatory (near London) has been adopted as the *Prime Meridian* by an international agreement and has been given the value of  $0^\circ$ .

The *longitude* of a place is its angular distance east or west of the Prime Meridian. It is also measured in degrees. The longitudes vary from  $0^\circ$  to  $180^\circ$



eastward and westward of the Prime Meridian (Fig. 3.3). The part of the earth east of the Prime Meridian is called the eastern hemisphere and in its west referred to as the western hemisphere.

### Drawing the Meridians of Longitude

How to draw the lines of longitude? Draw a circle whose centre represents the North Pole. The circumference will represent the equator. Draw a vertical line through the centre of the circle, i.e. crossing the North Pole. This represents the  $0^\circ$  and  $180^\circ$  meridians, which meet at the North Pole (Fig. 3.4).

When you look at a map, the east is towards your right and the west is towards your left. However, to draw a longitude, imagine that you are on the North Pole, i.e. at the centre of the circle as shown in Fig. 3.4. Observe now that the relative directions of east and west would reverse in this case and east would be towards your left while west would be towards your right. Now, draw  $45^\circ$  E and W as shown in Fig. 3.5. For this, place your protractor along the vertical line, coinciding with the  $0^\circ$  and  $180^\circ$  meridians and then measure  $45^\circ$  on both the sides, which will denote  $45^\circ$  E meridian and  $45^\circ$  W meridian on your left and right, respectively. The diagram will represent the appearance of the earth if we look at it from directly above the North Pole.

### LONGITUDE AND TIME

We all know that the earth rotates from west to east over its axis. It makes the sun rise in the east and set in the west. The rotation of the earth over its axis takes 24 hours to complete one circle or  $360^\circ$  of longitudes. As  $180^\circ$  of longitudes fall both east and west of the Prime Meridian, the sun, thus takes 12 hours' time to traverse the

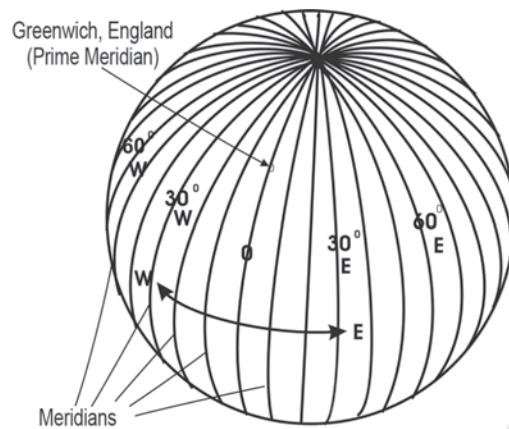

Figure 3.3 Meridians of Longitude

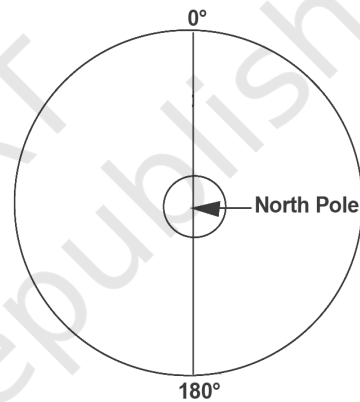

Figure 3.4 Meridians of  $0^\circ$  and  $180^\circ$  join at the North Pole

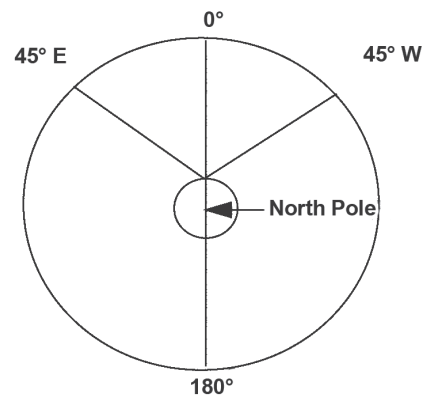

Figure 3.5 Drawing of Meridians of Longitude

*Table 3.1 A Comparison between the Parallels of Latitudes and the Meridians of Longitudes*

S. No.	Parallels of Latitude	Meridians of Longitude
1.	Latitude is the angular distance of a point north or south of the equator as measured in degrees.	Longitude is the angular distance along the equator measured in degrees. It is measured east or west of Greenwich (0°), from 0° to 180°.
2.	All latitudes are parallel to the equator.	All meridians of longitude converge at the poles.
3.	On a globe, parallels of latitudes appear as circles.	All meridians of longitude appear as circles running through the poles.
4.	The distance between two latitudes is approximately 111 km.	The distance between two longitudes is maximum at the equator (111.3 km) and minimum at the poles (0 km). Midway, at 45° of latitude, it is 79 km.
5.	The 0° latitude is referred to as the equator and the 90° as the poles.	There are 360° of longitude, 180° each in the east and west of the Prime Meridian.
6.	The latitudes from the equator to the poles are used to demarcate temperature zones, i.e. 0° to 23 ½° north and south as the torrid zone, 23 ½° to 66 ½° as the temperate zone and 66 ½° to 90° as the frigid	The longitudes are used to determine the local time with reference to the time at Prime Meridian.

eastern and western hemispheres. In other words, the sun traverses  $15^\circ$  of longitudes per hour or one degree of longitude in every four minutes of time. It may further be noted that the time decreases when we move from west to east and increases with our westward movement.

The rate of the time at which the sun traverses over certain degrees of longitudes is used to determine the local time of an area with respect to the time at the Prime Meridian ( $0^\circ$  Longitude). Let us try to understand the question of the determination of time with respect to the Prime Meridian with the following set of examples :

**Example 1 :** Determine the local time of Thimpu (Bhutan) located at  $90^\circ$  east longitude when the time at Greenwich ( $0^\circ$ ) is 12.00 noon.

**Statement :** The time increases at a rate of 4 minutes per one degree of longitude, east of the Prime Meridian.

**Solution :**

Difference between Greenwich and Thimpu =  $90^\circ$  of longitudes  
Total Time difference =  $90 \times 4 = 360$  minutes  
=  $360/60$  hours  
= 6 hours \Local time of Thimpu is 6 hours more than that at Greenwich, i.e. 6.00 p.m.

**Example 2 :** Determine the local time of New Orleans (the place, which was worst affected by Katrina Hurricane in October 2005), located at  $90^\circ$  West longitude when the time at Greenwich ( $0^\circ$ ) is 12.00 noon.

**Statement :** The time decrease, at a rate of 4 minutes per one degree of longitude, west of the prime meridian.

**Solution :**

Difference between Greenwich and New Orleans =  $90^\circ$  of longitudes  
Total Time difference =  $90 \times 4 = 360$  minutes  
=  $360/60$  hours  
= 6 hours \Local time of New Orleans is 6 hours less than that at Greenwich, i.e. 6.00 a. m.

In the same way, the time may be determined for any place in the world. However, in order to maintain uniformity of time as far as possible within the territorial limits of a country, the time at the central meridian of the country is taken as the Standard Meridian and its local time is taken as the *standard time* for the whole country. The Standard Meridian is selected in a manner that it is divisible by  $150^\circ$  or  $7^\circ 30'$  so that the difference

between its *standard time* and the *Greenwich Mean Time* may be expressed as multiples of an hour or half an hour.

The Indian Standard Time is calculated from 82°30'E meridian passing through Mirzapur. Therefore, IST is plus 5.30 hours from the GMT ((82°30' x 4) (60 minutes=5 hours 30 minutes). Similarly, all countries of the world choose the standard meridian within their territory to determine the time within their administrative boundaries. The countries with large east-west span may choose more than one standard meridian to get more than one time zone such as Russia, Canada and the United States of America. The world is divided into 24 major time zones (Fig. 3.6).

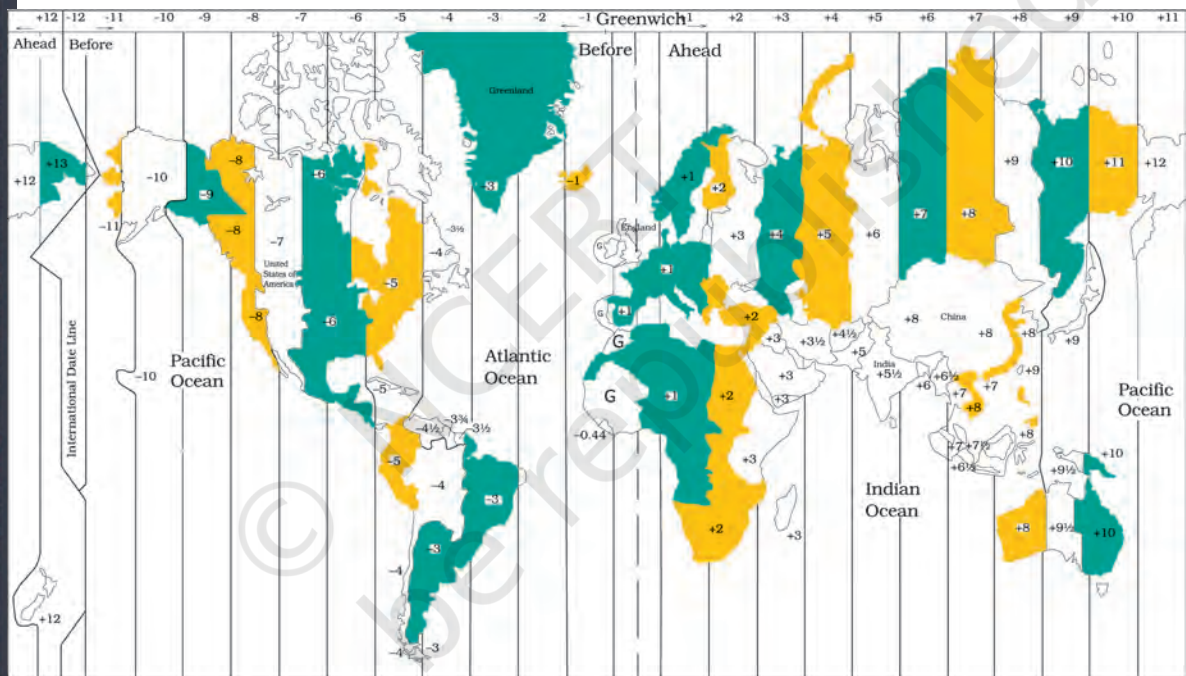

Figure 3.6 Major Time Zones of the World

### INTERNATIONAL DATE LINE

While the world is divided into 24 time zones, there has to be a place where there is a difference in days, somewhere the day truly “starts” on the planet. The 180° line of longitude is approximately where the International Date Line passes. The time at this longitude is exactly 12 hours from the 0° longitude, irrespective of one travels westward or eastward from the Prime Meridian. We know that time increases east of

the Prime Meridian and decreases to its west. Hence, for a person moving east of the Prime Meridian, the time would be 12 hours less than the time at  $0^\circ$  longitude. For another person moving westward, the time would be 12 hours more than the Prime Meridian. For example, a person moving eastward on Tuesday will count the day as Wednesday once the International Date Line is crossed. Similarly, another person starting his journey on the same day, but moving westward will count the day as Monday after crossing the line.

---

### EXERCISE

1. Answer the following questions in about 30 words:
  - (i) Which are the two natural points of references on the earth?
  - (ii) What is a great circle?
  - (iii) What are coordinates?
  - (iv) Why does the sun appear to be moving from east to west?
  - (v) What is meant by local time?
2. Distinguish between latitudes and longitudes.

### ACTIVITY

1. Find out the locations of the following places with the help of your atlas and write their latitudes and longitudes.

	Place	Latitude	Longitude
(i)	Mumbai		
(ii)	Vladivostok		
(iii)	Cairo		
(iv)	New York		
(v)	Ottawa		
(vi)	Geneva		
(vii)	Johannesburg		
(viii)	Sydney		

2. What would be the time of the following cities if the time at Prime Meridian is 10 a.m.
- (i) Delhi
  - (ii) London
  - (iii) Tokyo
  - (iv) Paris
  - (v) Cairo
  - (vi) Moscow



## Chapter 4



# Map Projections

What is map projection? Why are map projections drawn? What are the different types of projections? Which projection is most suitably used for which area? In this chapter, we will seek the answers of such essential questions.

### MAP PROJECTION

Map projection is the method of transferring the graticule of latitude and longitude on a plane surface. It can also be defined as the transformation of spherical network of parallels and meridians on a plane surface. As you know that, the earth on which we live in is not flat. It is geoid in shape like a sphere. A globe is the best model of the earth. Due to this property of the globe, the shape and sizes of the continents and oceans are accurately shown on it. It also shows the directions and distances very accurately. The globe is divided into various segments by the lines of latitude and longitude. The horizontal lines represent the parallels of latitude and the vertical lines represent the meridians of the longitude. The network of parallels and meridians is called *graticule*. This network facilitates drawing of maps. Drawing of the *graticule* on a flat surface is called projection.

But a globe has many limitations. It is expensive. It can neither be carried everywhere easily nor can a minor detail be shown on it. Besides, on the globe the meridians are semi-circles and the parallels are circles. When they are transferred on a plane surface, they become intersecting straight lines or curved lines.

## NEED FOR MAP PROJECTION

The need for a map projection mainly arises to have a detailed study of a region, which is not possible to do from a globe. Similarly, it is not easy to compare two natural regions on a globe. Therefore, drawing accurate large-scale maps on a flat paper is required. Now, the problem is how to transfer these lines of latitude and longitude on a flat sheet. If we stick a flat paper over the globe, it will not coincide with it over a large surface without being distorted. If we throw light from the centre of the globe, we get a distorted picture of the globe in those parts of paper away from the line or point over which it touches the globe. The distortion increases with increase in distance from the tangential point. So, tracing all the properties like shape, size and directions, etc. from a globe is nearly impossible because the globe is not a developable surface.

In map projection we try to represent a good model of any part of the earth in its true shape and dimension. But distortion in some form or the other is inevitable. To avoid this distortion, various methods have been devised and many types of projections are drawn. Due to this reason, map projection is also defined as the study of different methods which have been tried for transferring the lines of *graticule* from the globe to a flat sheet of paper.

### Glossary

**Map projection:** It is the system of transformation of the spherical surface onto a plane surface. It is carried out by an orderly and systematic representation of the parallels of latitude and the meridians of longitude of the spherical earth or part of it on a plane surface on a conveniently chosen scale.

**Lexodrome or Rhumb Line:** It is a straight line drawn on Mercator's projection joining any two points having a constant bearing. It is very useful in determining the directions during navigation.

**The Great Circle:** It represents the shortest route between two points, which is often used both in air and ocean navigation.

**Homolographic Projection:** A projection in which the network of latitudes and longitudes is developed in such a way that every *graticule* on the map is equal in area to the corresponding *graticule* on the globe. It is also known as the equal-area projection.

**Orthomorphic Projection:** A projection in which the correct shape of a given area of the earth's surface is preserved.



## ELEMENTS OF MAP PROJECTION

**a. Reduced Earth:** A model of the earth is represented by the help of a reduced scale on a flat sheet of paper. This model is called the “reduced earth”. This model should be more or less spheroid having the length of polar diameter lesser than equatorial and on this model the network of *graticule* can be transferred.

**b. Parallels of Latitude:** These are the circles running round the globe parallel to the equator and maintaining uniform distance from the poles. Each parallel lies wholly in its plane which is at right angle to the axis of the earth. They are not of equal length. They range from a point at each pole to the circumference of the globe at the equator. They are demarcated as  $0^{\circ}$  to  $90^{\circ}$  North and South latitudes.

**c. Meridians of Longitude:** These are semi-circles drawn in north-south direction from one pole to the other, and the two opposite meridians make a complete circle, i.e. circumference of the globe. Each meridian lies wholly in its plane, but all intersect at right angle along the axis of the globe. There is no obvious central meridian but for convenience, an arbitrary choice is made, namely the meridian of Greenwich, which is demarcated as  $0^{\circ}$  longitudes. It is used as reference longitudes to draw all other longitudes

**d. Global Property:** In preparing a map projection the following basic properties of the global surface are to be preserved by using one or the other methods:

- (i) Distance between any given points of a region;
- (ii) Shape of the region;
- (iii) Size or area of the region in accuracy;
- (iv) Direction of any one point of the region bearing to another point.

## CLASSIFICATION OF MAP PROJECTIONS

Map Projections may be classified on the following bases:

**a. Drawing Techniques:** On the basis of method of construction, projections are generally classified into perspective, non-perspective and

conventional or mathematical. *Perspective projections* can be drawn taking the help of a source of light by projecting the image of a network of parallels and meridians of a globe on developable surface. *Non-perspective projections* are developed without the help of a source of light or casting shadow on surfaces, which can be flattened. *Mathematical or conventional projections* are those, which are derived by mathematical computation, and formulae and have little relations with the projected image.

**b. Developable Surface:** A developable surface is one, which can be flattened, and on which, a network of latitude and longitude can be projected. A non-developable surface is one, which cannot be flattened without shrinking, breaking or creasing. A globe or spherical surface has the property of non-developable surface whereas a cylinder, a cone and a plane have the property of developable surface. On the basis of nature of developable surface, the projections are classified as cylindrical, conical and zenithal projections. *Cylindrical projections* are made through the use of cylindrical developable surface. A paper-made cylinder covers the

globe, and the parallels and meridians are projected on it. When the cylinder is cut open, it provides a cylindrical projection on the plane sheet. A *Conical projection* is drawn by wrapping a cone round the globe and the shadow of *graticule* network is projected on it. When the cone is cut open, a projection is obtained on a flat sheet. *Zenithal projection* is directly obtained on a plane surface when plane touches the globe at a point and the *graticule* is projected on it. Generally, the plane is so placed on the globe that it touches the globe at one of the poles. These projections are further subdivided into normal, oblique or polar as per the position of the plane touching the globe. If the developable surface touches the globe at the equator, it is called the

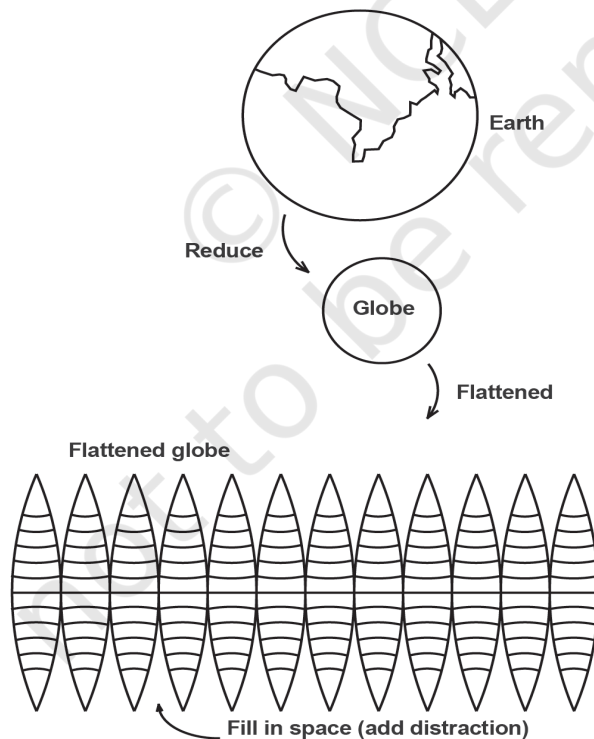

Figure 4.1 Conversions from a Globe to a flat surface produces distortions in area, shape and directions.

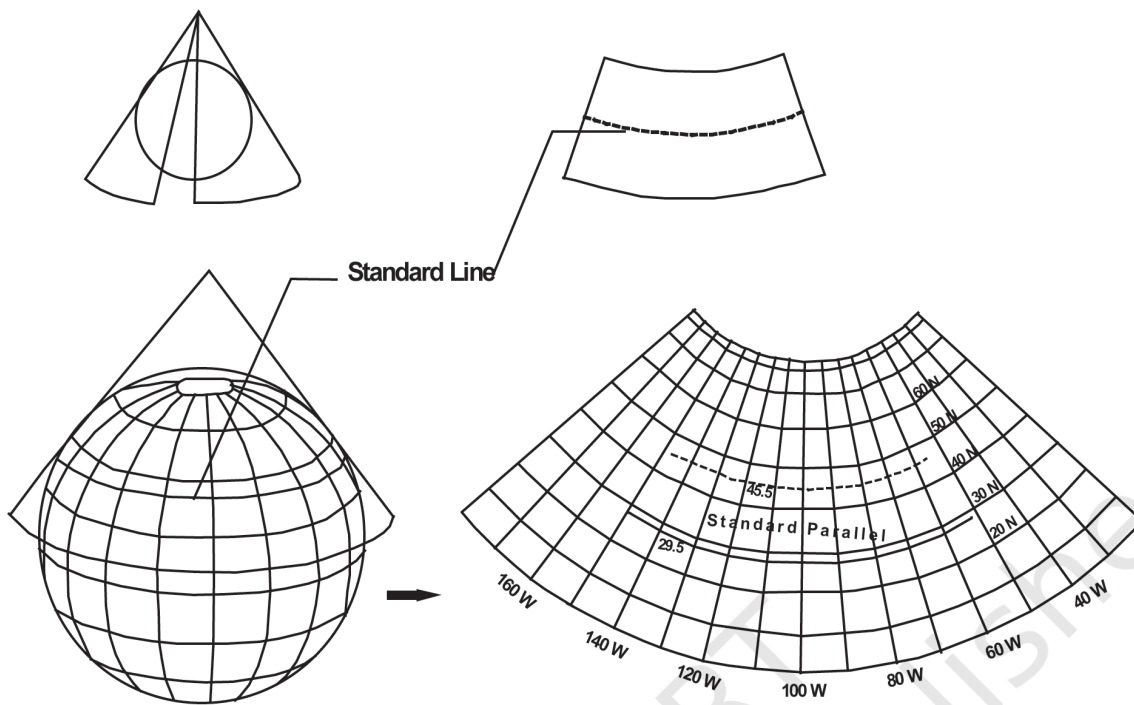

Figure 4.2 A conical projection from a Globe to a Flat Map

*equatorial or normal projection*. If it is tangential to a point between the pole and the equator, it is called the *oblique projection*; and if it is tangential to the pole, it is called the *polar projection*.

**c. Global Properties:** As mentioned above, the correctness of area, shape, direction and distances are the four major global properties to be preserved in a map. But none of the projections can maintain all these properties simultaneously. Therefore, according to specific need, a projection can be drawn so that the desired quality may be retained. Thus, on the basis of global properties, projections are classified into equal area, orthomorphic, azimuthal and equi-distant projections. *Equal Area Projection* is also called *homolographic* projection. It is that projection in which areas of various parts of the earth are represented correctly. *Orthomorphic or True-Shape* projection is one in which shapes of various areas are portrayed correctly. The shape is generally maintained at the cost of the correctness of area. *Azimuthal or True-Bearing* projection is one on which the direction of all points from the centre is correctly represented. *Equi-distant or True Scale* projection is that where the distance or scale is correctly maintained. However, there is no such projection, which maintains the scale correctly throughout. It can be

maintained correctly only along some selected parallels and meridians as per the requirement.

**d. Source of Light:** On the basis of location of source of light, projections may be classified as gnomonic, stereographic and orthographic. *Gnomonic projection* is obtained by putting the light at the centre of the globe. *Stereographic projection* is drawn when the source of light is placed at the periphery of the globe at a point diametrically opposite to the point at which the plane surface touches the globe. *Orthographic projection* is drawn when the source of light is placed at infinity from the globe, opposite to the point at which the plane surface touches the globe.

### CONSTRUCTING SOME SELECTED PROJECTIONS

#### a. Conical Projection with one Standard Parallel

A conical projection is one, which is drawn by projecting the image of the *graticule* of a globe on a developable cone, which touches the globe along a parallel of latitude called the *standard parallel*. As the cone touches the globe located along AB, the position of this parallel on the globe coinciding with that on the cone is taken as the *standard parallel*. The length of other parallels on either side of this parallel are distorted. (Fig. 4.3)

#### Example

Construct a conical projection with one standard parallel for an area bounded by 10° N to 70° N latitude and 10° E to 130° E longitudes when the scale is 1:250,000,000 and latitudinal and longitudinal interval is 10°.

#### Calculation

$$\text{Radius of reduced earth } R = \frac{640,000,000}{250,000,000} = 2.56 \text{ cm}$$

Standard parallel is 40° N (10, 20, 30, **40**, 50, 60, 70)

Central meridian is 70° E (10, 20, 30, 40, 50, 60, **70**, 80, 90, 100, 110, 120, 130)

#### Construction

- (i) Draw a circle or a quadrant of 2.56 cm radius marked with angles COE as 10° interval and BOE and AOD as 40° *standard parallel*.
- (ii) A tangent is extended from B to P and similarly from A to P, so that AP and BP are the two sides of the cone touching the globe and forming Standard Parallel at 40° N.

- (iii) The arc distance CE represents the interval between parallels. A semi-circle is drawn by taking this arc distance.
- (iv) X-Y is the perpendicular drawn from OP to OB.
- (v) A separate line N-S is taken on which BP distance is drawn representing standard parallel. The line NS becomes the central meridian.
- (vi) Other parallels are drawn by taking arc distance CE on the central meridian.
- (vii) The distance XY is marked on the standard parallel at  $40^\circ$  for drawing other meridians.
- (viii) Straight lines are drawn by joining them with the pole.

**Properties**

- 1. All the parallels are arcs of concentric circle and are equally spaced.
- 2. All meridians are straight lines merging at the pole. The meridians intersect the parallels at right angles.
- 3. The scale along all meridians is true, i.e. distances along the meridians are accurate.
- 4. An arc of a circle represents the pole.
- 5. The scale is true along the standard parallel but exaggerated away from the standard parallel.
- 6. Meridians become closer to each other towards the pole.
- 7. This projection is neither equal area nor orthomorphic.

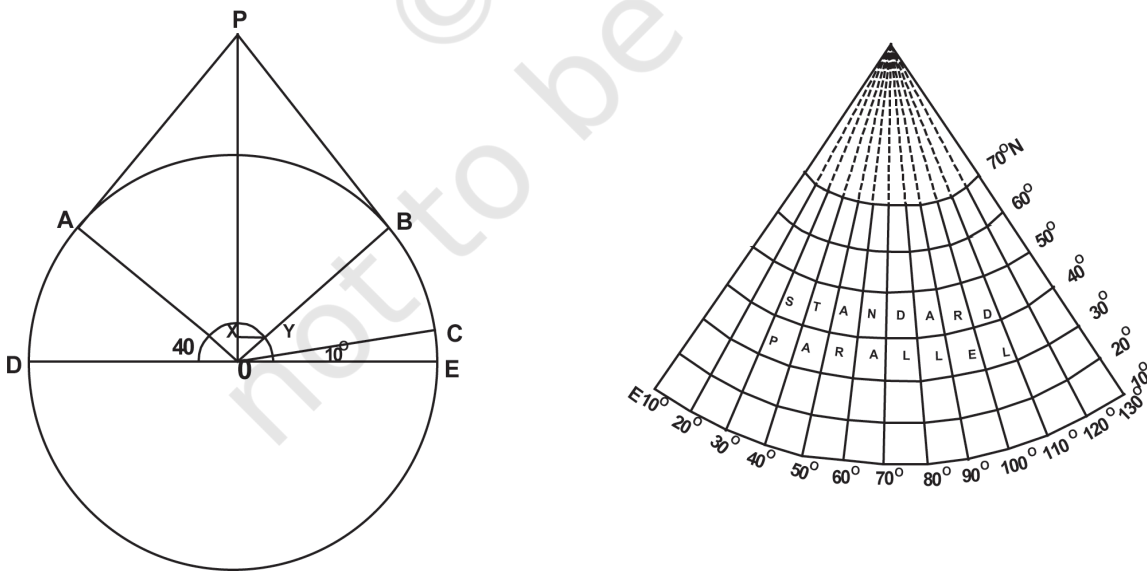

Figure 4.3 Simple Conical Projection with one standard parallel

**Limitations**

1. It is not suitable for a world map due to extreme distortions in the hemisphere opposite the one in which the standard parallel is selected.
2. Even within the hemisphere, it is not suitable for representing larger areas as the distortion along the pole and near the equator is larger.

**Uses**

1. This projection is commonly used for showing areas of mid-latitudes with limited latitudinal and larger longitudinal extent.
2. A long narrow strip of land running parallel to the standard parallel and having east-west stretch is correctly shown on this projection.
3. Direction along standard parallel is used to show railways, roads, narrow river valleys and international boundaries.
4. This projection is suitable for showing the Canadian Pacific Railways, Trans-Siberian Railways, international boundaries between USA and Canada and the Narmada Valley.

**b. Cylindrical Equal Area Projection**

The cylindrical equal area projection, also known as the *Lambert's projection*, has been derived by projecting the surface of the globe with parallel rays on a cylinder touching it at the equator. Both the parallels and meridians are projected as straight lines intersecting one another at right angles. The pole is shown with a parallel equal to the equator; hence, the shape of the area gets highly distorted at the higher latitude.

**Example**

Construct a cylindrical equal area projection for the world when the R.F. of the map is 1:300,000,000 taking latitudinal and longitudinal interval as 15°.

**Calculation**

$$\text{Radius of the reduced earth } R = \frac{640,000,000}{300,000,000} = 2.1 \text{ cm}$$

$$\text{Length of the equator } 2\pi R \text{ or } \frac{2 \times 22 \times 2.1}{7} = 13.2 \text{ cm}$$

$$\text{Interval along the equator} = \frac{13.2 \times 15^\circ}{360^\circ} = 0.55 \text{ cm}$$

### Construction

- (i) Draw a circle of 2.1 cm radius;
- (ii) Mark the angles of  $15^\circ$ ,  $30^\circ$ ,  $45^\circ$ ,  $60^\circ$ ,  $75^\circ$  and  $90^\circ$  for both, northern and southern hemispheres;
- (iii) Draw a line of 13.2 cm and divide it into 24 equal parts at a distance of 0.55cm apart. This line represents the equator;
- (iv) Draw a line perpendicular to the equator at the point where  $0^\circ$  is meeting the circumference of the circle;
- (v) Extend all the parallels equal to the length of the equator from the perpendicular line; and
- (vi) Complete the projection as shown in fig 4.4 below:

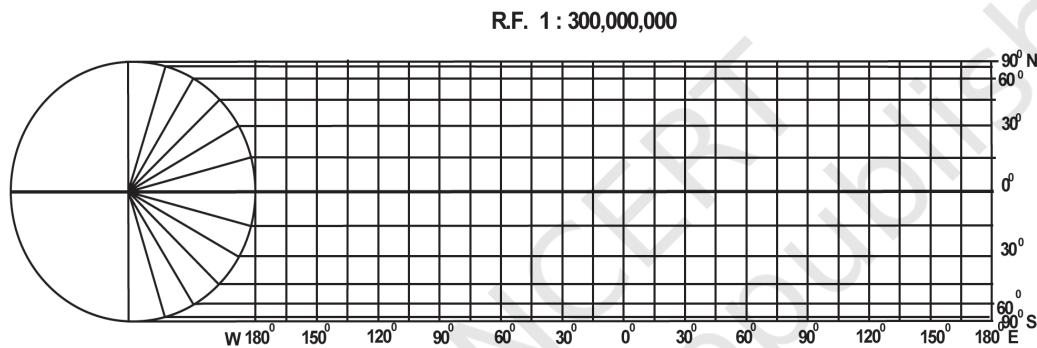

Figure 4.4 Cylindrical Equal Area Projection

### Properties

1. All parallels and meridians are straight lines intersecting each other at right angle.
2. Polar parallel is also equal to the equator.
3. Scale is true only along the equator.

### Limitations

1. Distortion increases as we move towards the pole.
2. The projection is non-orthomorphic.
3. Equality of area is maintained at the cost of distortion in shape.

### Uses

1. The projection is most suitable for the area lying between  $45^\circ$  N and S latitudes.
2. It is suitable to show the distribution of tropical crops like rice, tea, coffee, rubber and sugarcane.

### c. Mercator's Projection

A Dutch cartographer Mercator Gerardus Karter developed this projection in 1569. The projection is based on mathematical formulae. So, it is an orthomorphic projection in which the correct shape is maintained. The distance between parallels increases towards the pole. Like cylindrical projection, the parallels and meridians intersect each other at right angle. It has the characteristics of showing correct directions. A straight line joining any two points on this projection gives a constant bearing, which is called a *Laxodrome* or *Rhumb line*.

#### Example

Draw a Mercator's projection for the world map on the scale of 1:250,000,000 at 15° interval.

#### Calculation

$$\text{Radius of the reduced earth is } R = \frac{250,000,000}{250,000,000} = 1'' \text{ inch}$$

$$\text{Length of the equator } 2\pi R \text{ or } \frac{1 \times 22 \times 2}{7} = 6.28'' \text{ inches}$$

$$\text{Interval along the equator} = \frac{6.28 \times 15^\circ}{360^\circ} = 0.26'' \text{ inches}$$

#### Construction

- (i) Draw a line of 6.28'' inches representing the equator as EQ:
- (ii) Divide it into 24 equal parts. Determine the length of each division using the following formula:

$$\frac{\text{Length of Equator} \times \text{interval}}{360}$$

- (iii) Calculate the distance for latitude with the help of the table given below:-

Latitude	Distance
15°	$0.265 \times 1 = 0.265''$ inch
30°	$0.549 \times 1 = 0.549''$ inch
45°	$0.881 \times 1 = 0.881''$ inch
60°	$1.317 \times 1 = 1.317''$ inches
75°	$2.027 \times 1 = 2.027''$ inches

- (iv) Complete the projection as shown in Fig. 4.5



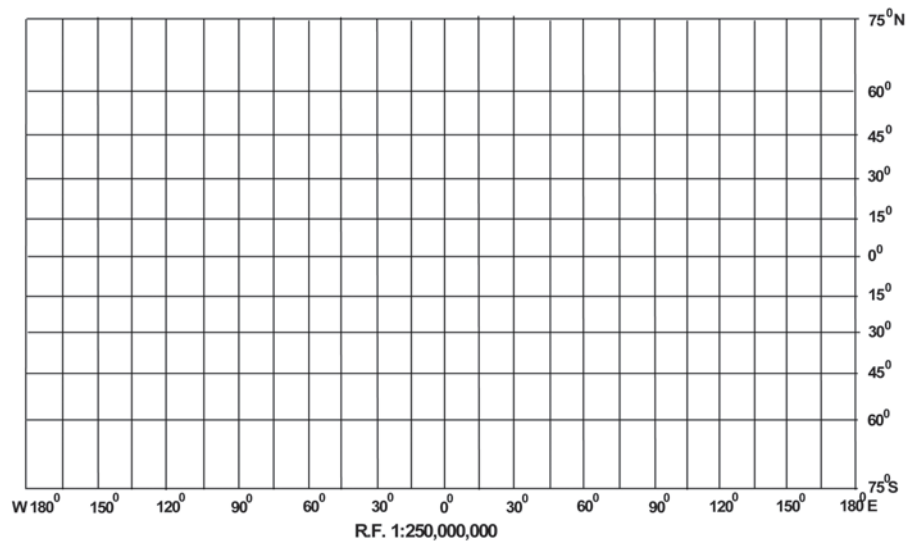

Figure 4.5 Mercator's Projection

### Properties

1. All parallels and meridians are straight lines and they intersect each other at right angles.
2. All parallels have the same length which is equal to the length of equator.
3. All meridians have the same length and equal spacing. But they are longer than the corresponding meridian on the globe.
4. Spacing between parallels increases towards the pole.
5. Scale along the equator is correct as it is equal to the length of the equator on the globe; but other parallels are longer than the corresponding parallel on the globe; hence the scale is not correct along them. For example, the 30° parallel is 1.154 times longer than the corresponding parallel on the globe.
6. Shape of the area is maintained, but at the higher latitudes distortion takes place.
7. The shape of small countries near the equator is truly preserved while it increases towards poles.
8. It is an azimuthal projection.
9. This is an orthomorphic projection as scale along the meridian is equal to the scale along the parallel.

### Limitations

1. There is greater exaggeration of scale along the parallels and meridians in high latitudes. As a result, size of the countries near

the pole is highly exaggerated. For example, the size of Greenland equals to the size of USA, whereas it is 1/10th of USA.

2. Poles in this projection cannot be shown as 90° parallel and meridian touching them are infinite.

**Uses**

1. More suitable for a world map and widely used in preparing atlas maps.
2. Very useful for navigation purposes showing sea routes and air routes.
3. Drainage pattern, ocean currents, temperature, winds and their directions, distribution of worldwide rainfall and other weather elements are appropriately shown on this map

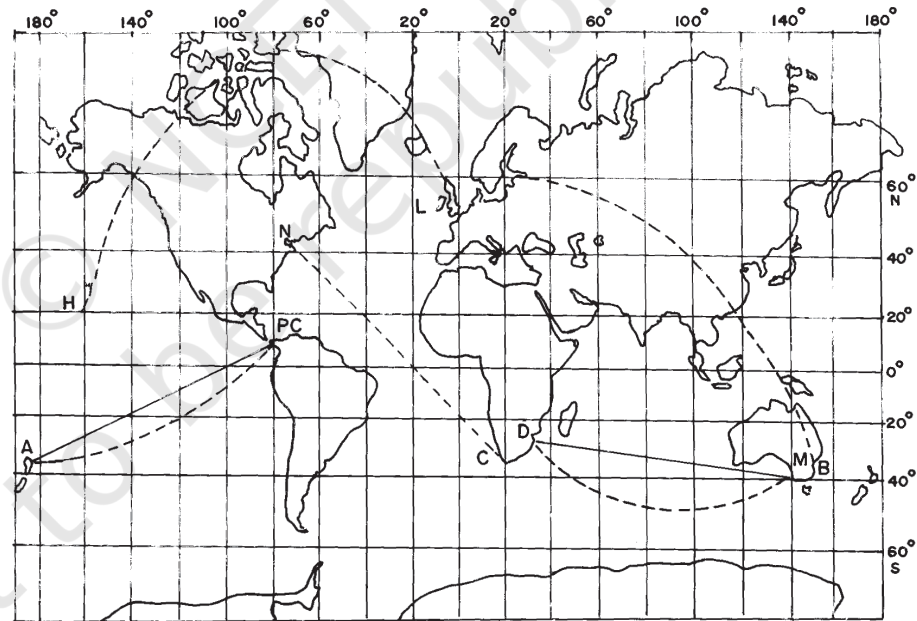

Figure 4.6 Straight lines are Loxodromes or Rhumb lines and Dotted lines are great circles

## EXERCISE

1. Choose the right answer from the four alternatives given below:

- (i) A map projection least suitable for the world map:
  - (a) Mercator
  - (b) Simple Cylindrical
  - (c) Conical
  - (d) All the above
- (ii) A map projection that is neither the equal area nor the correct shape and even the directions are also incorrect
  - (a) Simple Conical
  - (b) Polar zenithal
  - (c) Mercator
  - (d) Cylindrical
- (iii) A map projection having correct direction and correct shape but area greatly exaggerated polewards is
  - (a) Cylindrical Equal Area
  - (b) Mercator
  - (c) Conical
  - (d) All the above
- (iv) When the source of light is placed at the centre of the globe, the resultant projection is called
  - (a) Orthographic
  - (b) Stereographic
  - (c) Gnomonic
  - (d) All the above

2. Answer the following questions in about 30 words:

- (i) Describe the elements of map projection.
- (ii) What do you mean by global property?
- (iii) Not a single map projection represents the globe truly. Why?
- (iv) How is the area kept equal in cylindrical equal area projection?

3. Differentiate between—

- (i) Developable and non-developable surfaces
- (ii) Homolographic and orthographic projections
- (iii) Normal and oblique projections
- (iv) Parallels of latitude and meridians of longitude

4. Answer the following questions in not more than 125 words:
- Discuss the criteria used for classifying map projection and state the major characteristics of each type of projection.
  - Which map projection is very useful for navigational purposes? Explain the properties and limitations of this projection.
  - Discuss the main properties of conical projection with one standard parallel and describe its major limitations.

### ACTIVITY

Construct *graticule* for an area stretching between  $30^{\circ}$  N to  $70^{\circ}$  N and  $40^{\circ}$  E to  $30^{\circ}$  W on a simple conical projection with one standard parallel with a scale of 1:200,000,000 and interval at an  $10^{\circ}$  apart.

Prepare *graticule* for a Cylindrical Equal Area Projection for the world when R.F. is 1: 150,000,000 and the interval is  $15^{\circ}$  apart.

Draw a Mercator Projection for the world map when the R.F. is 1:400,000,000 and the interval between the latitude and longitude is  $20^{\circ}$ .



## Chapter 5



# Topographical Maps

You know that the map is an important geographic tool. You also know that maps are classified on the basis of scale and functions. The topographical maps, which have been referred to in Chapter 1 are of utmost importance to geographers. They serve the purpose of base maps and are used to draw all the other maps.

Topographical maps, also known as general purpose maps, are drawn at relatively large scales. These maps show important natural and cultural features such as relief, vegetation, water bodies, cultivated land, settlements, and transportation networks, etc. These maps are prepared and published by the National Mapping Organisation of each country. For example, the Survey of India prepares the topographical maps in India for the entire country. The topographical maps are drawn in the form of series of maps at different scales. Hence, in the given series, all maps employ the same reference point, scale, projection, conventional signs, symbols and colours.

The topographical maps in India are prepared in two series, i.e. India and Adjacent Countries Series and The International Map Series of the World.

**India and Adjacent Countries Series:** Topographical maps under India and Adjacent Countries Series were prepared by the Survey of India till the coming into existence of Delhi Survey Conference in 1937. Henceforth, the preparation of maps for the adjoining countries was abandoned and the Survey of India confined itself to prepare and publish the topographical maps for India as per the specifications laid down for the International Map Series of the World. However, the Survey of India for the topographical maps

## Glossary

**Contours:** Imaginary lines joining all the points of equal elevation or altitude above mean sea level. They are also called “level lines”.

**Contour Interval:** Interval between two successive contours. It is also known as vertical interval, usually written as V. I. Generally, it is constant for a given map.

**Cross-section:** A side view of the ground cut vertically along a straight line. It is also known as a section or profile.

**Hachures:** Small straight lines drawn on the map along the direction of maximum slope, running across the contours. They give an idea about the differences in the slope of the ground.

**Topographic Map:** A map of a small area drawn on a large scale depicting detailed surface features both natural and man made. Relief in this map is shown by contours.

under the new series retained the numbering system and the layout plan of the abandoned India and Adjacent Countries Series.

The topographical maps of India are prepared on 1 : 10,00,000, 1 : 250,000, 1 : 1,25,000, 1 : 50,000 and 1 : 25,000 scale providing a latitudinal and longitudinal coverage of 4° × 4°, 1° × 1°, 30' × 30', 15' × 15' and 5' × 7' 30", respectively. The numbering system of each one of these topographical maps is shown in Fig. 5.1 (on page 51).

**International Map Series of the World:** Topographical Maps under International Map Series of the World are designed to produce standardised maps for the entire World on a scale of 1: 10,00,000 and 1:250,000.

**Reading of Topographical Maps:** The study of topographical maps is simple. It requires the reader to get acquainted with the legend, conventional sign and the colours shown on the sheets. The conventional sign and symbols depicted on the topographical sheets are shown in Fig. 5.2 (on page 52).

## METHODS OF RELIEF REPRESENTATION

The earth's surface is not uniform and it varies from mountains to hills to plateaus and plains. The elevation and depressions of the earth's surface are known as physical features or relief features of the earth. The map showing these features is called a relief map.

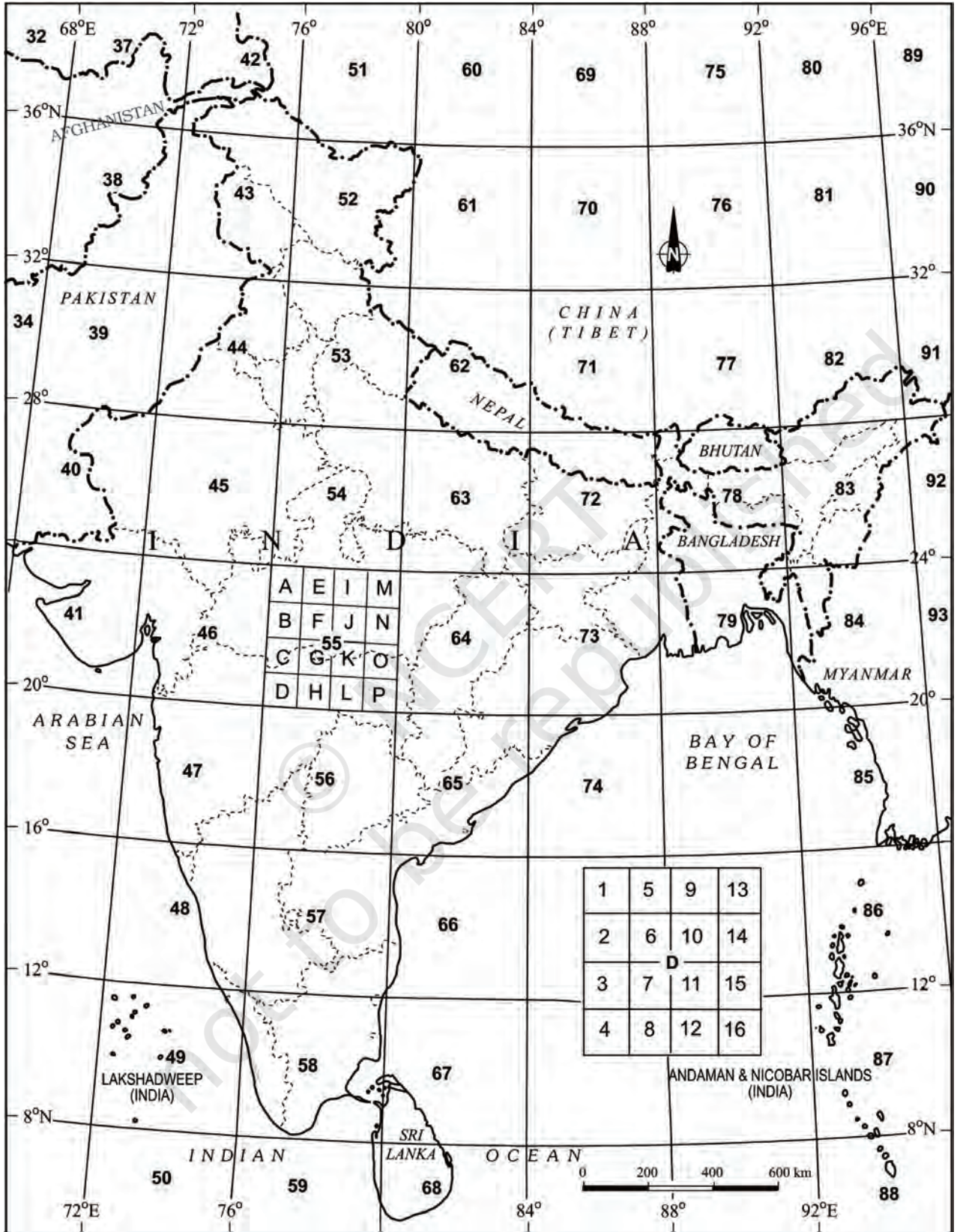

Figure 5.1 Reference Map of Topographical Sheets Published by Survey of India

Roads, metalled : according to importance; distance stone	
Roads, unmetalled : according to importance, bridge	
Cart-track. Pack-track and pass. Foot-path with bridge	
Streams : with track in bed; undefined. Canal	
Dams: masonry or rock-filled; earthwork. Weir	
River dry with water channel; with islands and rocks. Tidal river	
Swamp. Reeds	
Wells : lined; unlined. Spring. Tanks : perennial; dry	
Embankments : road or rail	
Railway, broad gauge : double; single with station; under construction	
Railway other gauges : double; single with distance stone; under constrn.	
Light Railway or tramway. Telegraph line. Cutting with tunnel	
Contours. Cliffs	
Sand features (1) flate (2) sand hills (permanent) (3) dunes (shifting)	
Towns or Villages : inhabited; deserted. Fort	
Huts : permanent; temporary. Tower. Antiquities	
Temple. Chhatri. Church. Mosque. Idgah. Tomb. Graves.	
Lighthouse. Lightship. Buoys : lighted; unlighted. Anchorage	
Mine. Vine on trellis. Grass. Scrub	
Palms : palmyra; other. Plantain. Conifer. Bamboo. Other trees.	
Boundary, international	
Boundary, state : demarcated; undemarcated	
Boundary, district : subdivision, tahsil or taluk; forest	
Boundary, pillars : surveyed; unlocated; village trijunction	
Heights, triangulated : station; point; approximate	
Bench-mark : geodetic; tertiary; canal	
Post office. Police station.	
Bungalows; dak or travellers; inspection. Rest-house	
Circuit house. Camping ground.	
Forest : reserved; protected	

Figure 5.2 Conventional Signs and Symbols

A number of methods have been used to show the relief features of the Earth's surface on maps, over the years. These methods include hachure, hill shading, layer tints, benchmarks and spot heights and contours. However, contours and spot heights are predominantly used to depict the relief of an area on all topographical maps.



## CONTOURS

Contours are imaginary lines joining places having the same elevation above mean sea level. A map showing the landform of an area by contours is called a *contour map*. The method of showing relief features through contour is very useful and versatile. The contour lines on a map provide a useful insight into the topography of an area.

Earlier, ground surveys and levelling methods were used to draw contours on topographical maps. However, the invention of photography and subsequent use of aerial photography have replaced the conventional methods of surveying, levelling and mapping. Henceforth, these photographs are used in topographical mapping.

Contours are drawn at different vertical intervals (VI), like 20, 50, 100 metres above the mean sea level. It is known as *contour interval*. It is usually constant on a given map. It is generally expressed in metres. While the vertical interval between the two successive contour lines remains constant, the horizontal distance varies from place to place depending upon the nature of slope. The horizontal distance, also known as the *horizontal equivalent* (HE), is large when the slope is gentler and decreases with increasing slope gradient.

### **Some basic features of contour lines are**

- ◇ A contour line is drawn to show places of equal heights.
- ◇ Contour lines and their shapes represent the height and slope or gradient of the landform.
- ◇ Closely spaced contours represent steep slopes while widely spaced contours represent gentle slope.
- ◇ When two or more contour lines merge with each other, they represent features of vertical slopes such as cliffs or waterfalls.
- ◇ Two contours of different elevation usually do not cross each other.

### **Drawing of Contours and Their Cross Sections**

We know that all the topographical features show varying degrees of slopes. For example, a flat plain exhibits gentler slopes and the cliffs and gorges are associated with the steep slopes. Similarly, valleys and mountain ranges are also characterised by the varying degree of slopes, i.e. steep to gentle. Hence, the spacing of contours is significant since it indicates the slope.

### Types of slope

The slopes can broadly be classified into gentle, steep, concave, convex and irregular or undulating. The contours of different types of slopes show a distinct spacing pattern.

**Gentle Slope**  
 When the degree or angle of slope of a feature is very low, the slope will be gentle. The contours representing this type of slope are far apart.



**Steep Slope**  
 When the degree or angle of slope of a feature is high and the contours are closely spaced, they indicate steep slope.

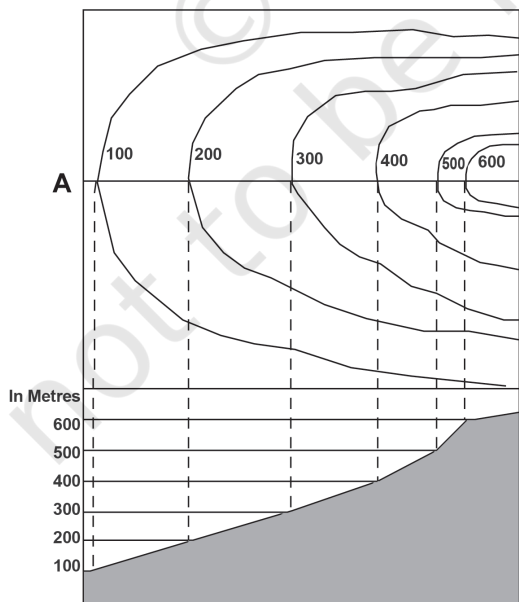

Gentle Slope

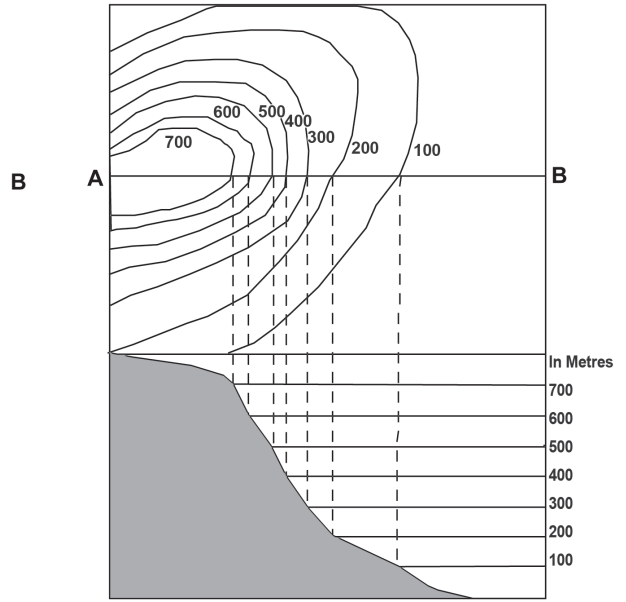

Steep Slope

**Concave Slope**

A slope with a gentle gradient in the lower parts of a relief feature and steep in its upper parts is called the *concave slope*. Contours in this type of slope are widely spaced in the lower parts and are closely spaced in the upper parts.



**Convex Slope**

Unlike concave slope, the *convex slope* is fairly gentle in the upper part and steep in the lower part. As a result, the contours are widely spaced in the upper parts and are closely spaced in the lower parts.

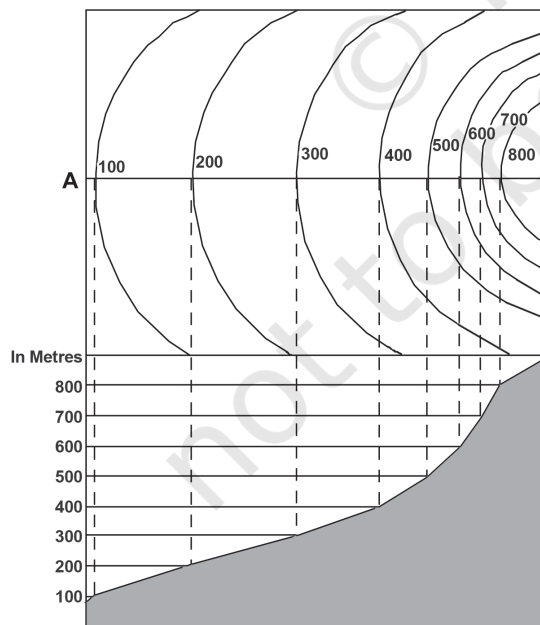

*Concave Slope*

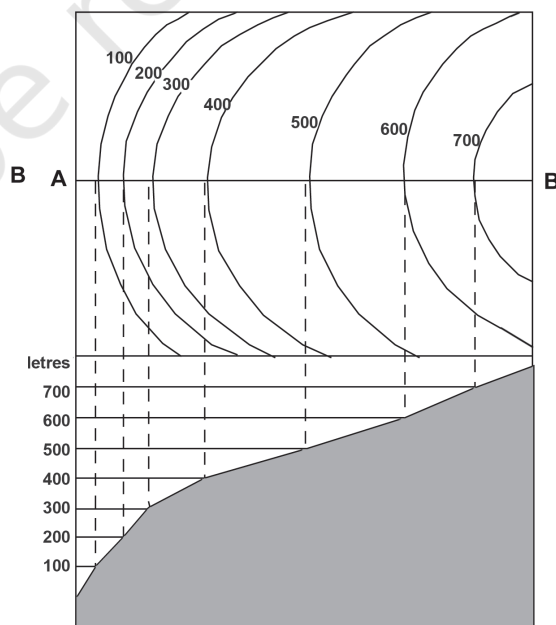

*Convex Slope*

### Types of Landform

#### Conical Hill

It rises almost uniformly from the surrounding land. A conical hill with uniform slope and narrow top is represented by concentric contours spaced almost at regular intervals.

#### Plateau

A widely stretched flat-topped high land, with relatively steeper slopes, rising above the adjoining plain or sea is called a *plateau*. The contour lines representing a plateau are normally close spaced at the margins with the innermost contour showing wide gap between its two sides.

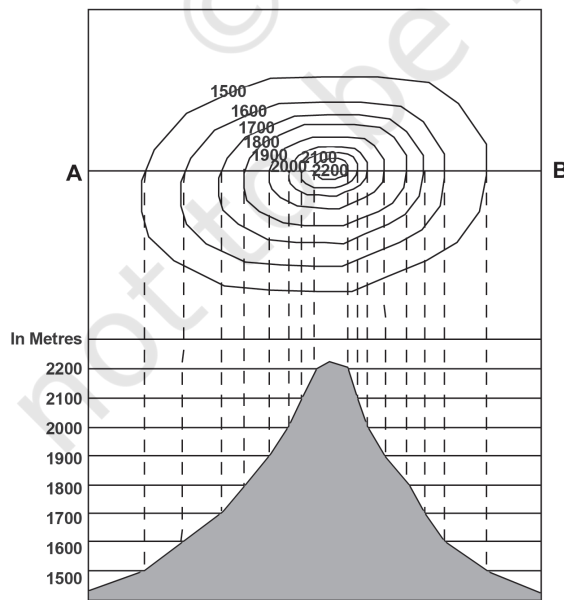

Conical Slope

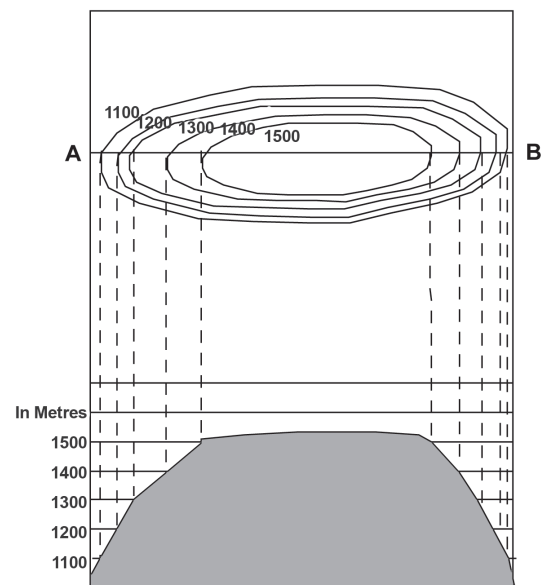

Plateau

## VALLEY

A geomorphic feature lying between two hills or ridges and formed as a result of the lateral erosion by a river or a glacier is called a *valley*.

### 'V'-shaped Valley

It resembles the letter V. A V-shaped valley occurs in mountainous areas. The lowermost part of the V-shaped valley is shown by the innermost contour line with very small gap between its two sides and the lowest value of the contour is assigned to it. The contour value increases with uniform intervals for all other contour lines outward.



### 'U' - shaped Valley

A U-shaped valley is formed by strong lateral erosion of glaciers at high altitudes. The flat wide bottom and steep sides makes it resemble the letter 'U'. The lowermost part of the U-shaped valley is shown by the innermost contour line with a wide gap between its two sides. The contour value increases with uniform intervals for all other contour lines outward.

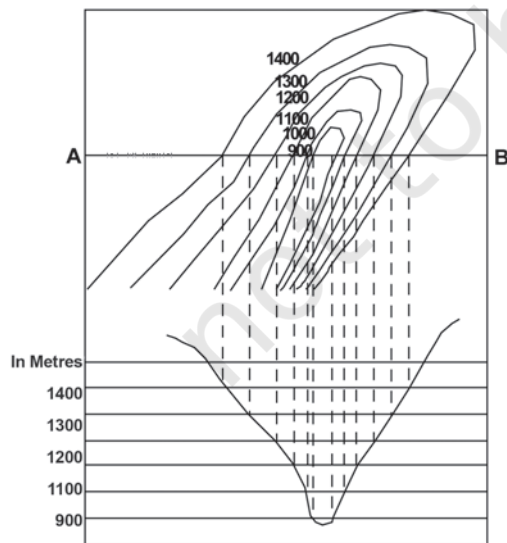

V-Shaped Valley

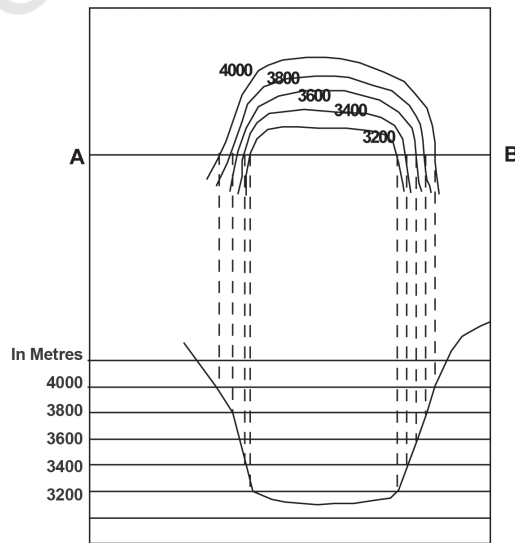

U-Shaped Valley

**Gorge**

In high altitudes, gorges form in the areas where the vertical erosion by river is more prominent than the lateral erosion. They are deep and narrow river valleys with very steep sides. A gorge is represented by very closely-spaced contour lines on a map with the innermost contour showing small gap between its two sides.



**Spur**

A tongue of land, projecting from higher ground into the lower is called a spur. It is also represented by V-shaped contours but in the reverse manner. The arms of the V point to the higher ground and the apex of 'V' to the lower ones.

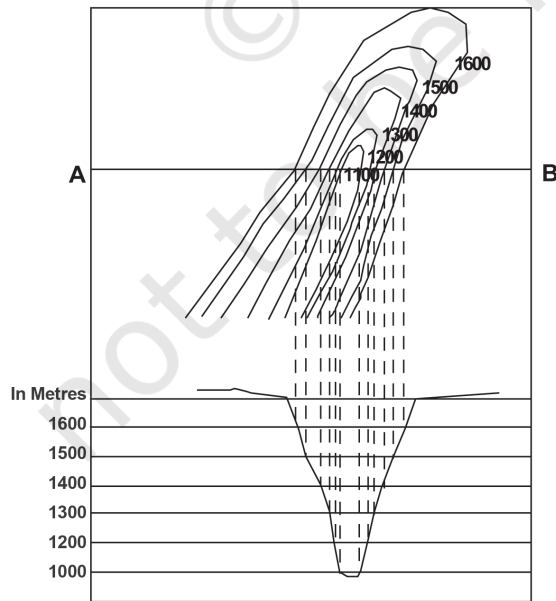

Gorge

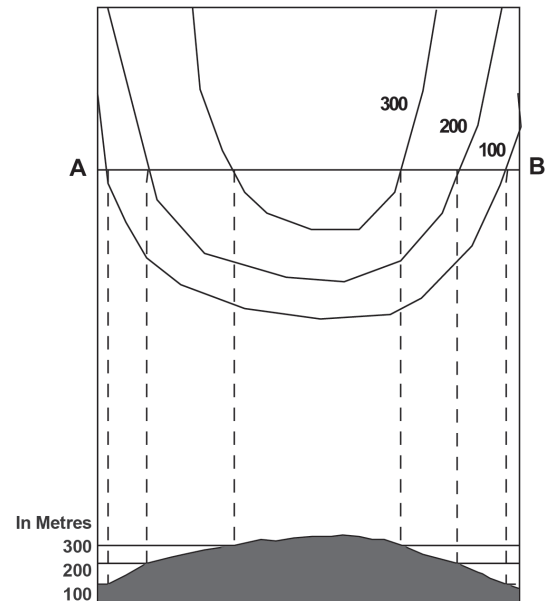

Spur

**CLIFF**

It is a very steep or almost perpendicular face of landform. On a map, a cliff may be identified by the way the contours run very close to one another, ultimately merging into one.

**Waterfall and Rapids**

A sudden and more or less perpendicular descent of water from a considerable height in the bed of a river is called a *waterfall*. Sometimes, a waterfall succeeds or precedes with a cascading stream forming *rapids* upstream or downstream of a waterfall. The contours representing a waterfall merge into one another while crossing a river stream and the rapids are shown by relatively distant contour lines on a map.

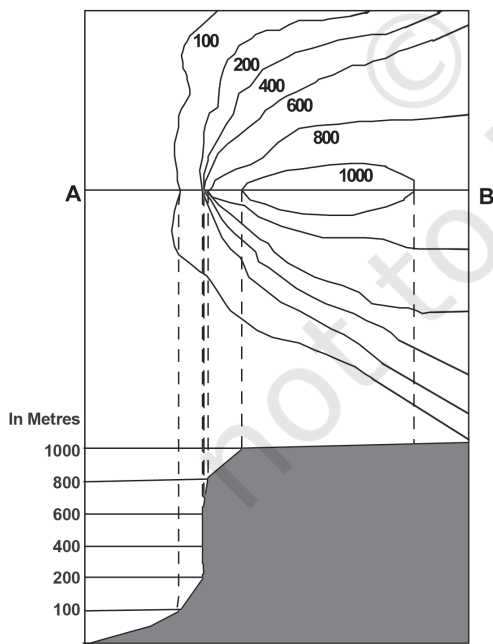

Cliff

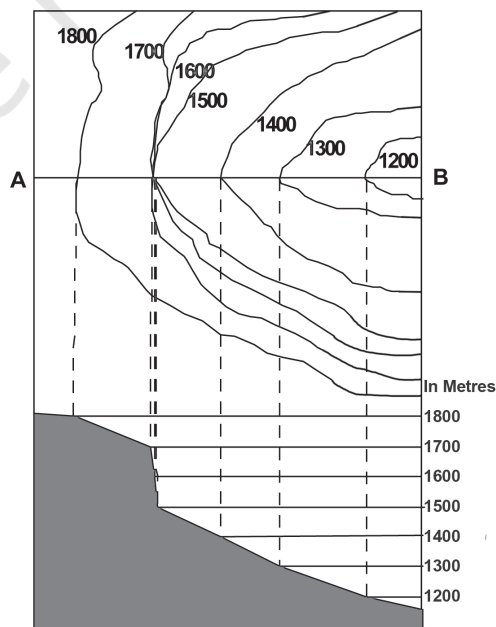

Waterfall

### **Steps for Drawing a Cross-section**

The following steps may be followed to draw cross-sections of various relief features from their contours :

1. Draw a straight line cutting across the contours on the map and mark it as AB.
2. Take a strip of white paper or graph and place its edge along the AB line.
3. Mark the position and value of every contour that cuts the line AB.
4. Choose a suitable vertical scale, eg  $\frac{1}{2}$  cm = 100 metres, to draw horizontal lines parallel to each other and equal to the length of AB. The number of such lines should be equal or more than the total contour lines.
5. Mark the appropriate values corresponding to the contour values along the vertical of the cross-section. The numbering may be started with the lowest value represented by the contours.
6. Now place the edge of the marked paper along the horizontal line at the bottom line of the cross-section in such a way that AB of the paper corresponds to the AB of the map and mark the contour points.
7. Draw perpendiculars from AB line, intersecting contour lines, to the corresponding line at the cross-section base.
8. Smoothly join all the points marked on different lines at the cross-section base.

### **IDENTIFICATION OF CULTURAL FEATURES FROM TOPOGRAPHICAL SHEETS**

Settlements, buildings, roads and railways are important cultural features shown on topographical sheets through conventional signs, symbols and colours. The location and pattern of distribution of different features help in understanding the area shown on the map.

#### ***Distribution Of Settlements***

It can be seen in the map through its site, location pattern, alignment and density. The nature and causes of various settlement patterns may be clearly understood by comparing the settlement map with the contour map.



Four types of rural settlements may be identified on the map

- (a) Compact
- (b) Scattered
- (c) Linear
- (d) Circular

Similarly, urban centres may also be distinguished as

- (a) Cross-road town
- (b) Nodal point
- (c) Market centre
- (d) Hill station
- (e) Coastal resort centre
- (f) Port
- (g) Manufacturing centre with suburban villages or satellite towns
- (h) Capital town
- (i) Religious centre

Various factors determine the *site* of settlements like

- (a) Source of water
- (b) Provision of food
- (c) Nature of relief
- (d) Nature and character of occupation
- (e) Defence

Site of settlements should be closely examined with reference to the contour and drainage map. Density of settlement is directly related to food supply. Sometimes, village settlements form alignments, i.e. they are spread along a river valley, road, embankment, coastline – these are called *linear settlements*.

In the case of an urban settlement, a cross-road town assumes a fan-shaped pattern, the houses being arranged along the roadside and the crossing being at the heart of the town and the main market place. In a nodal town, the roads radiate in all directions.

### **Transport And Communication Pattern**

Relief, population, size and resource development pattern of an area directly influence the means of transport and communication and their density. These are depicted through conventional signs and symbols. Means of transport and communication provide useful information about the area shown on the map.

## INTERPRETATION OF TOPOGRAPHICAL MAPS

Knowledge of map language and sense of direction are essential in reading and interpreting topo-sheets. You must first look for the northline and the scale of the map and orient yourself accordingly. You must have a thorough knowledge of the legends / key given in the map depicting various features. All topo-sheets contain a table showing conventional signs and symbols used in the map (Figure 5.2). Conventional signs and symbols are internationally accepted; so, anyone can read any map anywhere in the world without knowing the language of that particular country.

A topographic sheet is usually interpreted under the following heads:

- (a) Marginal Information
- (b) Relief and Drainage
- (c) Land Use
- (d) Means of Transport and Communication
- (e) Human Settlement

**Marginal Information:** It includes the topographical sheet number, its location, grid references, its extent in degrees and minutes, scale, the districts covered, etc.

**Relief of the Area:** The general topography of the area is studied to identify the plains, plateaus, hills or mountains along with peaks, ridges, *spur* and the general direction of the slope. These features are studied under the following heads :

- ◇ *Hill* : With concave, convex, steep or gentle slope and shape.
- ◇ *Plateau* : Whether it is broad , narrow, flat, undulating or dissected.
- ◇ *Plain* : Its types, i.e. alluvial, glacial, karst, coastal, marshy, etc.
- ◇ *Mountain* : General elevation, peak, passes, etc.

**Drainage of the Area:** The important rivers and their tributaries and the type and extent of valleys formed by them, the types of drainage pattern, i.e. dendritic, radial, ring, trellis, internal, etc.

**Land Use:** It includes the use of land under different categories like :

- ◇ Natural vegetation and forest (which part of the area is forested, whether it is dense forest or thin, and the categories of forest found there like Reserved, Protected, Classified / Unclassified).

- ◇ Agricultural, orchard, wasteland, industrial, etc.
- ◇ Facilities and Services such as schools, colleges, hospitals, parks, airports, electric substations, etc.

**Transport and Communication:** The means of transportation include national or state highways, district roads, cart tracks, camel tracks, footpaths, railways, waterways, major communication lines, post offices, etc.

**Settlement:** Settlements are studied under the following heads :

- ◇ Rural Settlements: The types and patterns of rural settlements, i.e. compact, semi-compact, dispersed, linear, etc.
- ◇ Urban Settlements: Type of urban settlements and their functions, i.e. capital cities, administrative towns, religious towns, port towns, hill stations, etc.

**Occupation:** The general occupation of the people of the area may be identified with the help of land use and the type of settlement. For example, in rural areas the main occupation of majority of the people is agriculture; in tribal regions, lumbering and primitive agriculture dominates and in coastal areas, fishing is practised. Similarly, in cities and towns, services and business appear to be the major occupations of the people.

## MAP INTERPRETATION PROCEDURE

Map interpretation involves the study of factors that explain the causal relationship among several features shown on the map. For example, the distribution of natural vegetation and cultivated land can be better understood against the background of landform and drainage. Likewise, the distribution of settlements can be examined in association with the levels of transport network system and the nature of topography.

The following steps will help in map interpretation:

- ◇ Find out from the index number of the topographical sheet, the location of the area in India. This would give an idea of the general characteristics of the major and minor physiographic divisions of the area. Note the scale of the map and the contour interval, which will give the extent and general landform of the area.

- ◇ Trace out the following features on tracing sheets.
  - (a) Major landforms – as shown by contours and other graphical features.
  - (b) Drainage and water features – the main river and its important tributaries.
  - (c) Land use – i.e. forest, agricultural land, wastes, sanctuary, park, school, etc.
  - (d) Settlement and Transport pattern.
- ◇ Describe the distributional pattern of each of the features separately drawing attention to the most important aspect.
- ◇ Superimpose pairs of these maps and note down the relationship, if any, between the two patterns. For example, if a contour map is superimposed over a land use map, it provides the relationship between the degree of slope and the type of the land used.

Aerial photographs and satellite imageries of the same area and of the same scale can also be compared with the topographical map to update the information.

---



---

### **EXERCISE**

1. Answer the following questions in about 30 words:
  - (i) What are topographical maps?
  - (ii) Name the organisation which prepares the topographical maps of India.
  - (iii) Which are the commonly used scales for mapping our country used by the Survey of India?
  - (iv) What are contours?
  - (v) What does the spacing of contours indicate?
  - (vi) What are conventional signs?
2. Write short notes on—
  - (i) Contours
  - (ii) 'Marginal Information' in Topographical sheets
  - (iii) The Survey of India
3. Explain what is meant by 'map interpretation' and what procedure is followed for its interpretation.

4. If you are interpreting the cultural features from a topographical sheet, what information would you like to seek and how would you derive this information? Discuss with the help of suitable examples.
5. Draw the conventional signs and symbols for the following features—
  - (i) International Boundary
  - (ii) Bench Mark
  - (iii) Villages
  - (iv) Metalled Road
  - (v) Footpath with bridges
  - (vi) Places of Worship
  - (vii) Railwayline

### Exercise A

Study the contour pattern and answer the following questions.

1. Name the geographical feature formed by contours.
2. Find out the contour interval in the map.
3. Find out the map distance between E and F and convert it into ground distance.
4. Name the type of slope between A and B; C and D and E and F.
5. Find out the direction of E, D and F from G.

### Exercise B

Study the extract from the topographical sheet No. 63K/12, as shown in the figure below and answer the following questions—

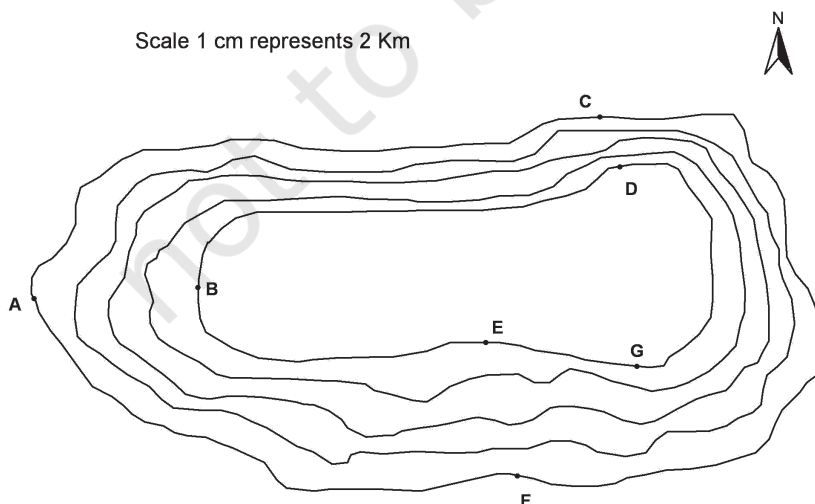

1. Convert 1:50,000 into a statement of scale.
2. Name the major settlements of the area.
3. What is the direction of flow of the river Ganga?

**Uttar Pradesh**

Mirzapur and Varanasi District

Part of 63K/12

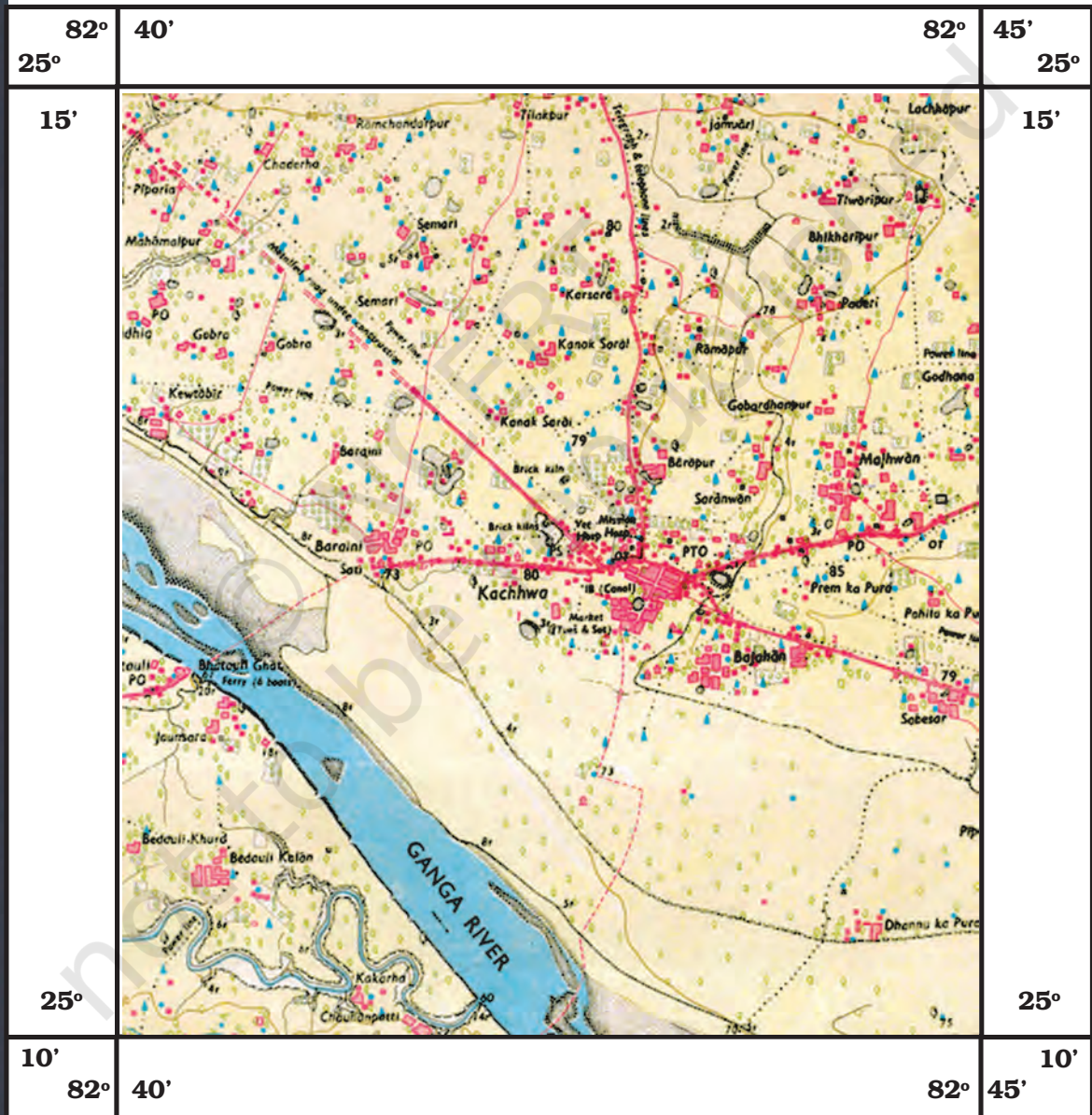

R. F. 1: 50,000

Part of the Topographical Sheet No 63K/12

4. At which one of the banks of river Ganga, Bhatauli is located ?
5. What is the pattern of rural settlements along the right bank of river Ganga?
6. Name the villages/settlements where Post Office is located ?
7. What does the yellow colour in the area refer to?
8. What means of transportation is used to cross the river by the people of Bhatauli village ?

### Exercise C

Study the extract for topographical sheet 63K/12 shown in the figure on page 68 and answer the following questions.

1. Give the height of the highest point on the map.
2. River Jantihwa Nadi is flowing through which quarter of the map ?
3. Which is the major settlement located in the east of the Kuardari Nala ?
4. What type of settlement does the area have ?
5. Name the geographical feature represented by white patches in the middle of Sipu Nadi.
6. Name the two types of vegetation shown on part of the topographical sheet.
7. What is the direction of the flow of the Kuardari ?
8. In which part of the sheet area is Lower Khajuri Dam located?

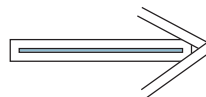

**Uttar Pradesh**

Mirzapur and Varanasi District

**Part of 63K/12**

68



R. F. 1: 50,000

Part of the Topographical Sheet No 63K/12





# Chapter 6



## Introduction To Remote Sensing

Both the human eyes and the photographic systems respond to light in a minute portion of the total energy received and responded by the objects' surface. The present day remote sensing devices, on the other hand, react to much wider range of radiations reflected/emitted, absorbed and transmitted by all object surfaces at a temperature above 0 Kelvin (-273 C).

The term remote sensing was first used in the early 1960s. Later, it was defined as the total processes used to acquire and measure the information of some property of objects and phenomena by a recording device (sensor) that is not in physical contact with the objects and phenomena in study. It can be noted from the above definition of remote sensing that it primarily involves an object surface, the recording device and the information carrying energy waves (Fig 6.1).

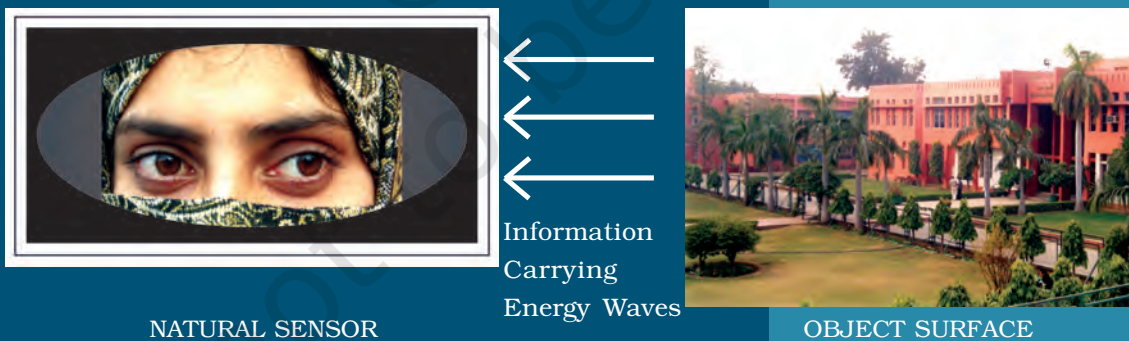

Figure 6.1 Conceptual Frame of Remote Sensing

## Glossary

**Absorptance** : The ratio of the radiant energy absorbed by a substance to the energy it receives.

**Band** : The specific wavelength interval in the electromagnetic spectrum.

**Digital image** : An array of digital numbers (DN) arranged in rows and columns, having the property of an intensity value and their locations.

**Digital Number** : An intensity value of a pixel in a digital image.

**Digital Image Processing** : The numerical manipulation of DN values for the purpose of extracting information about the phenomena of the surface they represent.

**Electromagnetic Radiation (EMR)** : The Energy propagated through a space or a medium at a speed of light.

**Electromagnetic Spectrum** : The continuum of EMR that ranges from short wave high frequency cosmic radiations to long wavelength low frequency radio waves.

**False Colour Composite (FCC)** : An artificially generated colour image in which blue, green and red colours are assigned to the wavelength regions to which they do not belong in nature. For example, in standard a False Colour Composite blue is assigned to green radiations (0.5 to 0.6  $\mu\text{m}$ ), green is assigned to red radiations (0.6 to 0.7  $\mu\text{m}$ ) and red is assigned to Near Infrared radiation (0.7 to 0.8  $\mu\text{m}$ ).

**Gray scale** : A medium to calibrate the variations in the brightness of an image that ranges from black to white with intermediate grey values.

**Image** : The permanent record of a scene comprising of natural and man-made features and activities, produced by photographic and non-photographic means.

**Scene** : The ground area covered by an image or a photograph.

**Sensor** : Any imaging or non-imaging device that receives EMR and converts it into a signal that can be recorded and displayed as photographic or digital image.

**Reflectance** : The ratio of the radiant energy reflected by a substance to the energy it receives.

**Spectral Band** : The range of the wavelengths in the continuous spectrum such as the green band ranges from 0.5 to .6  $\mu$  and the range of NIR band 0.7 to 1.1  $\mu$ .

## STAGES IN REMOTE SENSING

Figure 6.2 illustrates the processes used in remote sensing data acquisition. These basic processes that help in the collection of information about the properties of the objects and phenomena of the earth surface are as follows :

- (a) Source of Energy (sun/self-emission);
- (b) Transmission of energy from the source to the surface of the earth;
- (c) Interaction of energy with the earth's surface;
- (d) Propagation of reflected/emitted energy through atmosphere;
- (e) Detection of the reflected/emitted energy by the sensor;
- (f) Conversion of energy received into photographic/digital form of data;
- (g) Extraction of the information contents from the data products; and
- (h) Conversion of information into Map/Tabular forms.

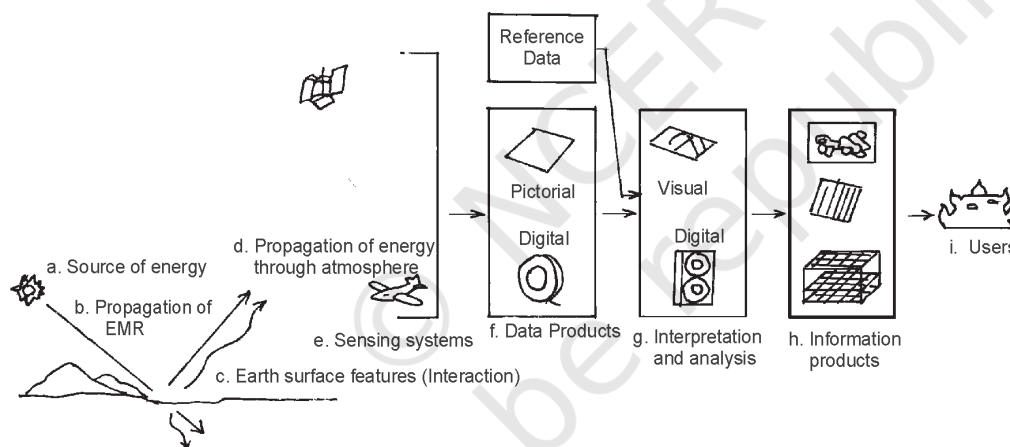

Figure 6.2 Stages in Remote Sensing Data Acquisition

**a. Source of Energy:** Sun is the most important source of energy used in remote sensing. The energy may also be artificially generated and used to collect information about the objects and phenomena such as flashguns or energy beams used in radar (radio detection and ranging).

**b. Transmission of Energy from the Source to the Surface of the Earth:** The energy that emanates from a source propagates between the source and the object surface in the form of the waves of

energy at a speed of light (300,000 km per second). Such energy propagation is called the *Electromagnetic Radiation* (EMR). The energy waves vary in size and frequency. The plotting of such variations is known as the *Electromagnetic Spectrum* (Fig. 6.3). On the basis of the size of the waves and frequency, the energy waves are grouped into Gamma, X-rays, Ultraviolet rays, Visible rays, Infrared rays, Microwaves and Radio waves. Each one of these broad regions of spectrum is used in different applications. However, the visible, infrared and microwave regions of energy are used in remote sensing.

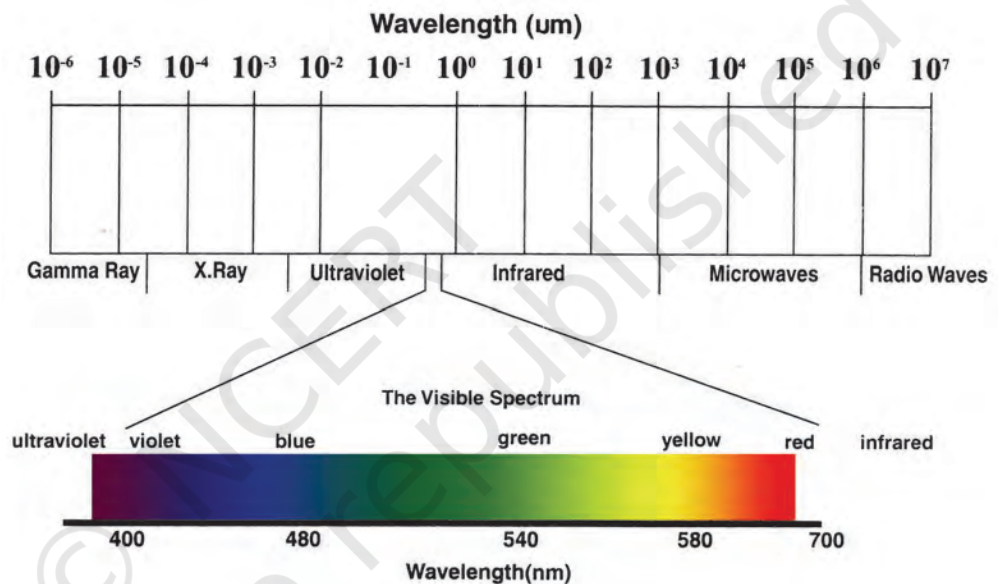

Figure 6.3 Electromagnetic Spectrum

**c. Interaction of Energy with the Earth's Surface:** The propagating energy finally interacts with the objects of the surface of the earth. This leads to absorption, transmission, reflection or emission of energy from the objects. We all know that all objects vary in their composition, appearance forms and other properties. Hence, the objects' responses to the energy they receive are also not uniform. Besides, one particular object also responds differently to the energy it receives in different regions of the spectrum (Fig. 6.5). For example, a fresh water body absorbs more energy in the red and infrared regions of the spectrum and appears dark/black in a satellite image whereas turbid water body reflects more in blue and green regions of spectrum and appears in light tone (Fig. 6.4).

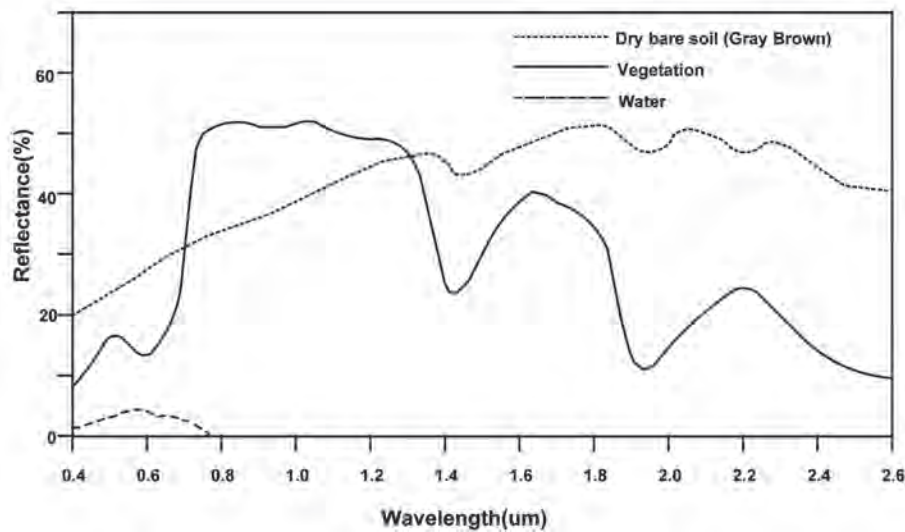

Figure 6.4 Spectral Signature of Soil, Vegetation and Water

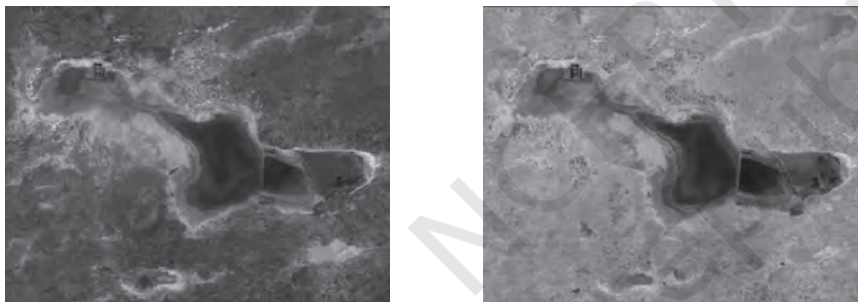

Figure 6.5 IRS 1 C Band 1 Green (Left) and Band 4 IR Images of Sambhar Lake, Rajasthan

**d. Propagation of Reflected/Emitted Energy through**

**Atmosphere:** When energy is reflected from objects of the earth's surface, it re-enters into the atmosphere. You may be aware of the fact that atmosphere comprises of gases, water molecules and dust particles. The energy reflected from the objects comes in contact with the atmospheric constituents and the properties of the original energy get modified. Whereas the Carbon dioxide (CO<sub>2</sub>), the Hydrogen (H), and the water molecules absorb energy in the middle infrared region, the dust particles scatter the blue energy. Hence, the energy that is either absorbed or scattered by the atmospheric constituents never reaches to sensor placed onboard a satellite and the properties of the objects carried by such energy waves are left unrecorded.

**e. Detection of Reflected/Emitted Energy by the Sensor:**

The sensors recording the energy that they receive are placed in a near-polar sun synchronous orbit at an altitude of 700 – 900 km. These satellites are known as remote sensing satellites (e.g. Indian Remote Sensing Series). As against these satellites, the weather monitoring and telecommunication satellites are placed in a Geostationary position (the satellite is always positioned over its orbit that synchronises with the direction of the rotation of the earth) and revolves around the earth (coinciding with the direction of the movement of the earth over its axis) at an altitude of nearly 36,000 km (e.g. INSAT series of satellites). A comparison between the remote sensing and weather monitoring satellites is given in Box (6.1). Figure 6.6 shows the orbits of Sun Synchronous and Geostationary satellites respectively.

**Box. 6.1 Comparison between Sun-Synchronous and Geostationary Satellites**

Orbital Characteristics	Sun Synchronous Satellites	Geostationary Satellites
Altitude	700 – 900 km	@ 36,000 km
Coverage	81°N to 81°S	1/3 <sup>rd</sup> of the Globe
Orbital period	@ 14 orbits per day	24 hours
Resolution	Fine (182 metre to 1 metre)	Coarse (1 km x 1 km)
Uses	Earth Resources Applications	Telecommunication and Weather monitoring

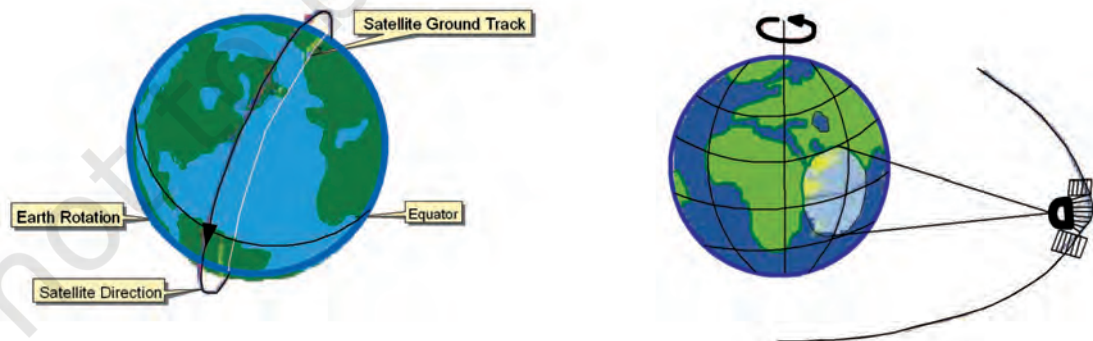

Figure 6.6 Orbit of Sun Synchronous (Left) and Geostationary (Right) Satellites

Remote sensing satellites are deployed with sensors which are capable of collecting the EMR reflected by the objects. Photographic camera obtains

photographs at an instance of exposure. However, the sensors used in remote sensing satellites possess a mechanism that is different from photographic camera in collecting and recording the information. The images so acquired by space-borne sensors are in digital format as against the photographic format obtained through a camera-based system.

***f. Conversion of Energy Received into Photographic/Digital Form of Data:*** The radiations received by the sensor are electronically converted into a digital image. It comprises digital numbers that are arranged in rows and columns. These numbers may also be converted into an analogue (picture) form of data product. The sensor onboard an earth-orbiting satellite electronically transmits the collected image data to an Earth Receiving Station located in different parts of the world. In India, one such station is located at Shadnagar near Hyderabad.

***g. Extraction of Information Contents from Data Products:*** After the image data is received at the earth station, it is processed for elimination of errors caused during image data collection. Once the image is corrected, information extraction is carried out from digital images using digital image processing techniques and from analogue form of data products by applying visual interpretation methods.

***h. Conversion of Information into Map/Tabular Forms:*** The interpreted information is finally delineated and converted into different layers of thematic maps. Besides, quantitative measures are also taken to generate a tabular data.

## SENSORS

A sensor is a device that gathers electromagnetic radiations, converts it into a signal and presents it in a form suitable for obtaining information about the objects under investigation. Based upon the form of the data output, the sensors are classified into photographic (analogue) and non-photographic (digital) sensors.

A photographic sensor (camera) records the images of the objects at an instance of exposure. On the other hand, a non-photographic sensor obtains the images of the objects in bit-by-bit form. These sensors are known as *scanners*. In the present chapter, we will confine ourselves to describe the non-photographic sensors that are used in satellite remote sensing.

**Multispectral Scanners:** In satellite remote sensing, the Multi Spectral Scanners (MSS) are used as sensors. These sensors are designed to obtain images of the objects while sweeping across the field of view. A scanner is usually made up of a reception system consisting of a mirror and detectors. A scanning sensor constructs the scene by recording a series of scan lines. While doing so, the motor device oscillates the scanning mirror through the angular field of view of the sensor, which determines the length of scan lines and is called *swath*. It is because of such reasons that the mode of collection of images by scanners is referred bit-by-bit. Each scene is composed of cells that determine the spatial resolution of an image. The oscillation of the scanning mirror across the scene directs the received energy to the detectors, where it is converted into electrical signals. These signals are further converted into numerical values called *Digital Number* (DN Values) for recording on a magnetic tape.

The Multi-Spectral Scanners are divided into the following types:

- (i) Whiskbroom Scanners
- (ii) Pushbroom Scanners

**(i) Whiskbroom Scanners :** The whiskbroom scanners are made up of a rotating mirror and a single detector. The mirror is so oriented that when it completes a rotation, the detector sweeps across the field of view

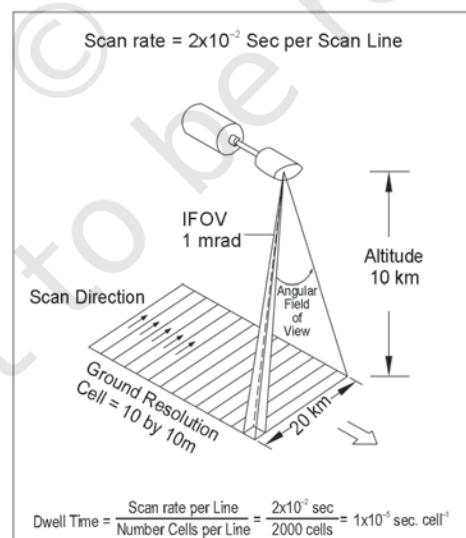

6.7 Whiskbroom Scanners

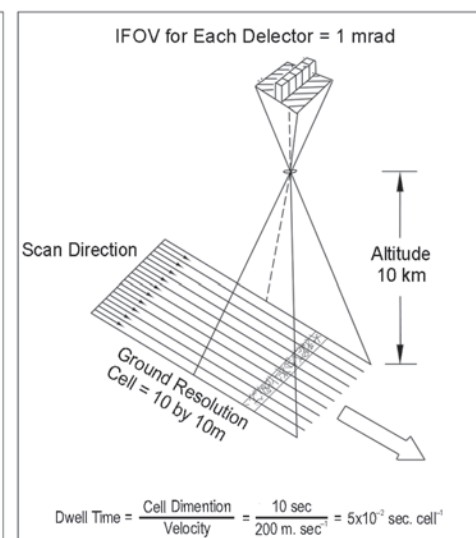

6.8 Pushbroom Scanners



between 90 and 120 to obtain images in a large number of narrow spectral bands ranging from visible to middle infrared regions of the spectrum. The total extent of the oscillating sensor is known as the Total Field of View (TFOV) of the scanner. While scanning the entire field, the sensor's optical head is always placed at a particular dimension called the Instantaneous Field of View (IFOV). Figure 6.7 depicts the scanning mechanism of whiskbroom scanners.

**(i) Pushbroom Scanners:** The pushbroom scanners consist of a number of detectors which are equivalent to the number obtained by dividing the *swath* of the sensor by the size of the spatial resolution (Fig. 6.8). For example, the *swath* of High Resolution Visible Radiometer – 1 (HRVR – 1) of the French remote sensing satellite SPOT is 60 km and the spatial resolution is 20 metres. If we divide 60 km x 1000 metres/20 metres, we get a number of 3000 detectors that are deployed in SPOT HRV – 1 sensor. In pushbroom scanner, all detectors are linearly arrayed and each detector collects the energy reflected by the ground cell (pixel) dimensions of 20 metres at a nadir's view.

## RESOLVING POWERS OF THE SATELLITES

In satellite remote sensing, the sun-synchronous polar orbit enables the collection of images after a pre-determined periodical interval referred to as the temporal resolution or the revisit time of the satellite over the same area of the earth surface. Fig. 6.9 illustrates the two images acquired over two different periods in time for the same area enabling to study and record the changes that take place with respect to the types of vegetation in Himalayas. In another example, Fig. 6.10 (a and b) shows the images acquired before and after the tsunami in the Indian Ocean. The image acquired in June 2004 clearly shows the undisturbed topography of Banda Aceh in Indonesia, whereas the post tsunami image acquired immediately after tsunami reveals the damages that were caused by the tsunami.

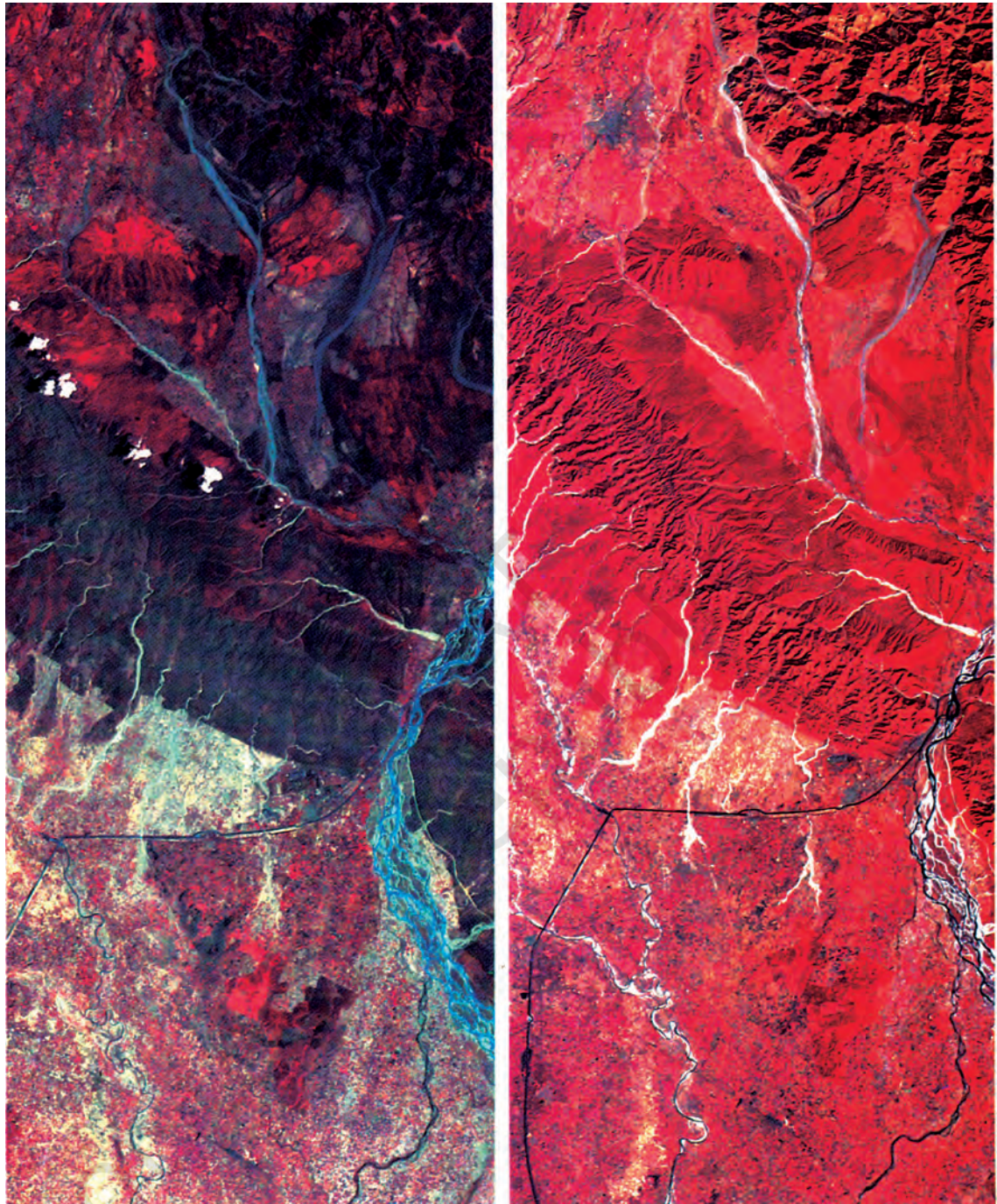

Figure 6. 9 Images of Himalayas and Northern Indian Plain by IRS Satellite taken in May (Left) and November (Right) show differences in the types of vegetation. The red patches in May image refer to Coniferous vegetation. In November image the additional red patches refer to Deciduous plants and the light red colour is related to the crops.



Figure 6.10 (a) Pre-tsunami Image acquired in June 2004



Figure 6.10 (b) Post-tsunami image acquired in December, 2004

## SENSOR RESOLUTIONS

Remote sensors are characterised by spatial, spectral and radiometric resolutions that enable the extraction of useful information pertaining to different terrain conditions.

**(i) Spatial Resolution:** You must have seen some people using spectacles while reading a book or newspaper. Have you ever thought as to why they do so. It is simply because of the fact that resolving power of their eyes to differentiate two closed spaced letters in a word is unable to identify them as two different letters. By using positive spectacles they try to improve their vision as well as the resolving power. In remote sensing, the spatial resolution of the sensors refers to the same phenomena. It is the capability of the sensor to distinguish two closed spaced object surfaces as two different object surfaces. As a rule, with an increasing resolution the identification of even smaller object surfaces become possible.

**(ii) Spectral Resolution:** It refers to the sensing and recording power of the sensor in different bands of EMR (Electromagnetic radiation). Multispectral images are acquired by using a device that disperses the radiation received by the sensor and recording it by deploying detectors sensitive to specific spectral ranges. The principles in obtaining such images is the extension of the dispersion of light in nature resulting in the appearance of the 'rainbow' and the use of prism in the lab (Box 6.2).

The images obtained in different bands show objects response differently as discussed in Para 3 of the stages in remote sensing data acquisition. Fig. 6.11 illustrates images acquired in different spectral regions by IRS P - 6 (Resource sat - 1) showing strong absorption properties of fresh water in band 4 (Infrared) and mixed strong reflectance in band 2 (green) by dry surfaces (Fig. 6.11).

**(iii) Radiometric Resolution:** It is the capability of the sensor to discriminate between two targets. Higher the radiometric resolution, smaller the radiance differences that can be detected between two targets.

The spatial, spectral, and radiometric resolutions of some of the remote sensing satellites of the world are shown in Table 6.1.

**Table 6.1 Spatial, Spectral and Radiometric Resolution of Landsat, IRS and SPOT Sensors**

Satellite/Sensor	Spatial Resolution (in metres)	Number of Bands	Radiometric Range (Number of Grey Level Variations)
Landsat MSS (USA)	80.0 × 80.0	4	0 - 64
IRS LISS - I (India)	72.5 × 72.5	4	0 - 127
IRS LISS - II (India)	36.25 × 36.25	4	0 - 127
Landsat TM (USA)	30.00 × 30.00	4	0 - 255
IRS LISS III (India)	23.00 × 23.00	4	0 - 127
SPOT HRV - I (France)	20.00 × 20.00	3	0 - 255
SPOT HRV - II (France)	10.00 × 10.00	1	0 - 255
IRS PAN (India)	5.80 × 5.80	1	0 - 127

**Box : 6.2**

**RAINBOW  
(Natural Dispersion of Light)**



**PRISM  
(Artificial Dispersion of Light)**

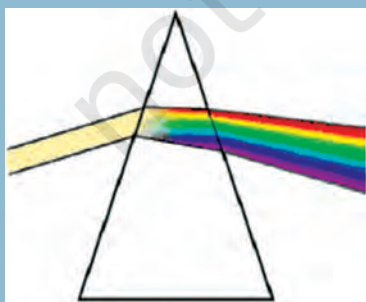

**Dispersion of Light**

**(The principle that is utilised in obtaining Multispectral Images)**

The overall mechanism of obtaining images in a number of bands derives strength from the principle of the dispersion of light. You must have seen the rainbow. It is formed through a natural process of dispersion of light rays through water molecules present in the atmosphere. The same phenomena may be experimented by putting a beam of light at one side of a prism. At the other side of the prism you may notice the dispersion of energy into seven colours that form white light.



Band 2 (Green) : 0.52–0.59 μm



Band 3 (Red) : 0.62–0.68 μm

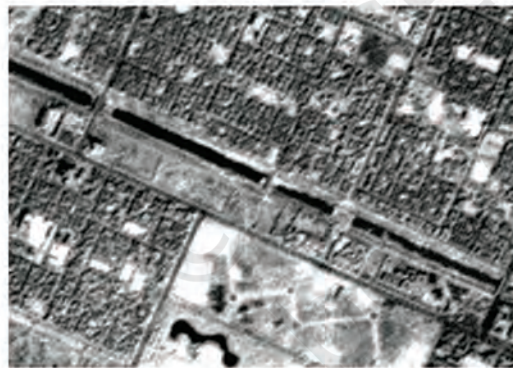

Band 4 (Infra Red) : 0.77–0.86 μm



Standard False Colour Composite

Figure 6. 11 IRS P - 6 (Resourcesat - 1) Images of Parts of Najafgarh, Delhi, 03 June 2005

## DATA PRODUCTS

We have seen that the electromagnetic energy may be detected either photographically or electronically. The photographic process uses light sensitive film to detect and record energy variations. On the other hand, a scanning device obtains images in digital mode. It is important to distinguish between the terms – images and photographs. An image refers to pictorial representation, regardless of what regions of energy have been used to detect and record it. A photograph refers specifically to images that have been recorded on photographic film. Hence, it can be said that all photographs are images, but all images are not photographs.

Based upon the mechanism used in detecting and recording, the remotely sensed data products may be broadly classified into two types :

- ◇ Photographic Images
- ◇ Digital Images

**Photographic Images:** Photographs are acquired in the optical regions of electromagnetic spectrum, i.e. 0.3 – 0.9  $\mu\text{m}$ . Four different types of light sensitive film emulsion bases are used to obtain photographs. These are black and white, colour, black and white infrared and colour infrared. However, in aerial photography black and white film is normally used. Photographs may be enlarged to any extent without losing information contents or the contrast.

**Digital Images:** A digital image consists of discrete picture elements called pixels. Each one of the pixels in an image has an intensity value and an address in two-dimensional image space. A digital number (DN) represents the average intensity value of a pixel. It is dependent upon the electromagnetic energy received by the sensor and the intensity levels used to describe its range.

In a digital image, the reproduction of the details pertaining to the images of the objects is affected by the size of the pixel. A smaller size pixel is generally useful in the preservation of the scene details and digital representation. However, zooming of the digital image beyond certain extent produces loss of information and the appearance of pixels only. Using a digital image processing algorithms, the digital numbers representing their intensity level in an image may be displayed (Fig. 6.12).

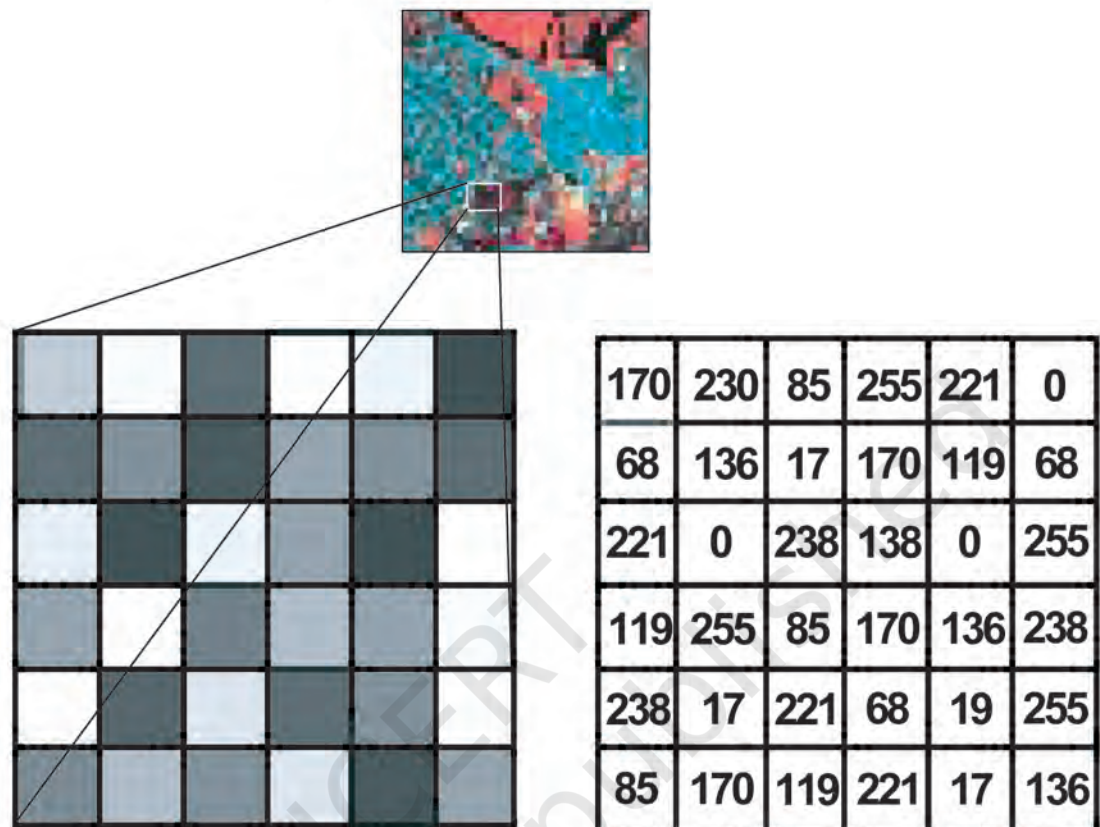

Figure 6.12 Digital Image (top) and Part of it zoomed showing Pixel's brightness (left) and the associated Digital Numbers (right)

### INTERPRETATION OF SATELLITE IMAGERIES

The data obtained from the sensors is used for information extraction related to the forms, and patterns of the objects and phenomena of the earth's surface. We have seen that different sensors obtain photographic and digital data products. Hence, the extraction of both qualitative and quantitative properties of such features could be carried out using either visual interpretation methods or digital image processing techniques.

The visual interpretation is a manual exercise. It involves reading of the images of objects for the purpose of their identification. On the other hand, digital images require a combination of hardware and software to extract the desired information. It would not be possible to deliberate upon the digital image processing techniques under the constraints of time, equipments and accessories. Hence, only visual interpretation methods would be discussed.



### ***Elements of Visual Interpretation***

Whether we are conscious of it or not we use the form, size, location of the objects and their relationships with the surrounding objects to identify them in our day-to-day life. These characteristics of objects are termed as elements of visual interpretation. We can further group the characteristics of the objects into two broad categories, i.e. image characteristics and terrain characteristics. The image characteristics include tone or colour in which objects appear, their shape, size, pattern, texture and the shadow they cast. On the other hand, location and the association of different objects with their surrounding objects constitute the terrain characteristics.

**1. Tone or Colour:** We know that all objects receive energy in all regions of spectrum. The interaction of EMR with the object surface leads to the absorption, transmittance and reflection of energy. It is the reflected amount of the energy that is received and recorded by the sensor in tones of grey, or hues of colour in black and white, and colour images respectively. The variations in the tone or the colour depend upon the orientation of incoming radiations, surface properties and the composition of the objects. In other words, smooth and dry object surfaces reflect more energy in comparison to the rough and moist surfaces. Besides, the response of the objects also varies in different regions of the spectrum (Refer para 'C – Stages in remote sensing data acquisition'). For example, healthy vegetation reflects strongly in the infrared region because of the multiple-layered leaf structure and appears in a light tone or bright red



6.13 (a) Turbid river



6.13 (b) River with fresh water

colour in standard false colour composite and the scrubs appear in greyish red colour). Similarly, a fresh water body absorbs much of the radiations received by it and appears in dark tone or black colour, whereas the turbid water body appears in light tone or light bluish colour in FCC due to mixed response shown by the water molecules as well as suspended sand particles (Figures 6.13 a and b).

The colours in which different features of the earth's surfaces are recorded in remote sensing images are given in Table 6.2.

**Table 6.2: Colour Signatures on Standard False Colour Composite of Earth Surface Features**

S. No.	Earth Surface Feature	Colour(In Standard FCC)
1.	<b>Healthy Vegetation and Cultivated Areas</b> Evergreen Deciduous Scrubs  Cropped land Fallow land	Red to magenta Brown to red Light brown with red patches Bright red Light blue to white
2.	<b>Waterbody</b> Clear water Turbid waterbody	Dark blue to black Light blue
3.	<b>Built – up area</b> High density Low density	Dark blue to bluish green Light blue
4.	<b>Waste lands/Rock outcrops</b> Rock outcrops Sandy deserts/River sand/ Salt affected Deep ravines Shallow ravines Water logged/Wet lands	Light brown Light blue to white  Dark green Light green Motelled black

**2. Texture:** The texture refers to the minor variations in tones of grey or hues of colour. These variations are primarily caused by an aggregation of smaller unit features that fail to be discerned individually such as high density and low density residential areas; slums and squatter settlements; garbage and other forms of solid waste; and different types of crops and plants. The textural differences in the images of certain objects vary from smooth to coarse textures (Fig. 6.14 a and b). For example, dense residential areas in a large city form fine texture due to the concentration of the houses in a smaller area and the low-density residential areas produce a coarse texture. Similarly, in high resolution images the sugarcane or millet plants produce coarse texture in comparison to the fine texture of rice or wheat plants. One can also notice the coarse texture in the images of scrubbed lands if compared with the fine texture of lush green evergreen forests.

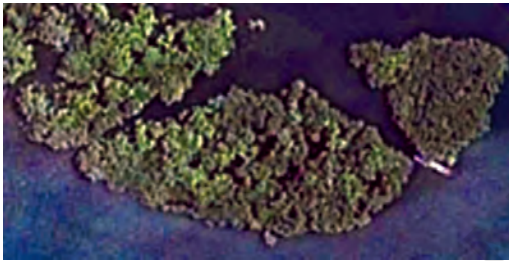

Figure 6.14 (a) Coarse texture image of mangroves

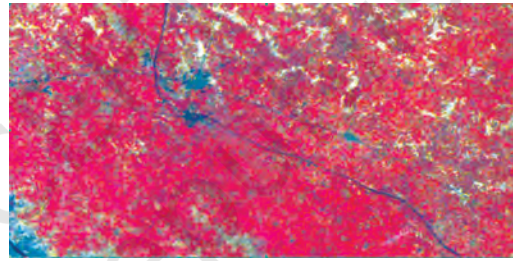

Figure 6.14 (b) Fine texture of cropped land

**3. Size:** The size of an object as discerned from the resolution or scale of an image is another important characteristic of individual objects. It helps in distinctively identifying the industrial and industrial complexes with residential dwellings (Fig. 6.15), stadium in the heart of the city with the brick kilns at an urban fringe, size and hierarchy of the settlements, etc.

**4. Shape:** The general form and configuration or an outline of an individual object provides important clues in the interpretation of remote sensing images. The shape of some of the objects is so distinctive that make them easy to identify. For example, the shape of the Sansad Bhawan is typically distinct from many other built-up features. Similarly, a railway line can be readily distinguished from a road due to its long continuous linearity in shape with gradual change in its course (Figure 6.16). The



(a) Parts of Kolkata

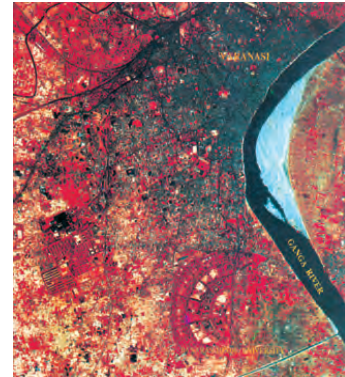

(b) Parts of Varanasi

Figure 6.15 Variations in size between institutional buildings and residential areas may be distinctly identified in the images of parts of Kolkata (a) and Varanasi (b)

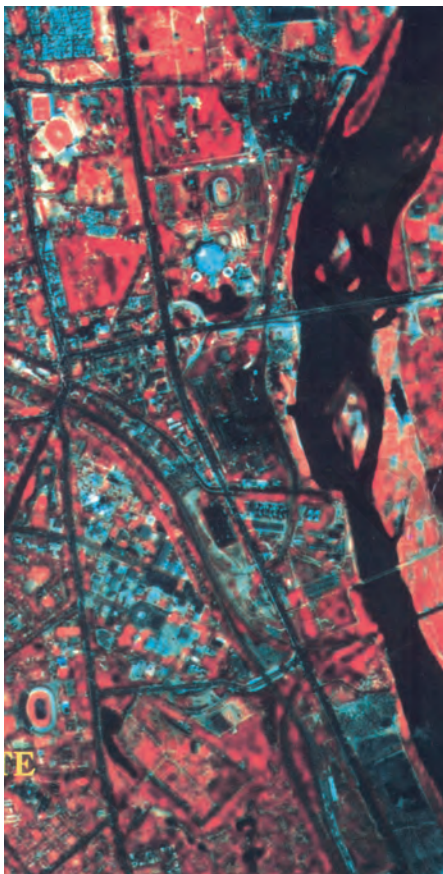

Figure 6.16 Curvilinear shape of the Railway Tract is Distinctly different from Sharp Bending Roads.

shape also plays a deciding role in the identity of religious places such as mosques and temples as distinct features.

**5. Shadow:** Shadow of an object is a function of the sun's illumination angle and the height of the object itself. The shape of some of the objects is so typical that they could not be identified without finding out the length of the shadow they cast. For example, the Qutub Minar located in Delhi, minarets of mosques, overhead water tanks, electric or telephone lines, and similar features can only be identified using their shadow. Shadow also adversely affects the identifiability of the objects in city centres as it produces a dark tone, which dominates the original tone or colour of the features lying under the shadow of tall buildings. It may, however, be noted that the shadow as an element of image interpretation is of less use in satellite images. However, it serves a useful purpose in large-scale aerial photography.

**6. Pattern:** The spatial arrangements of many natural and man-made features show repetitive

appearance of forms and relationships. The arrangements can easily be identified from the images through the utilisation of the pattern they form. For example, planned residential areas with the same size and layout plan of the dwelling units in an urban area can easily be identified if their pattern is followed (Figure 6.17). Similarly, orchards and plantations produce arrangements of the same type of plants with uniform inter – plant distances. A distinction can also be made between various types of drainage or settlements if their pattern is properly studied and recognised.

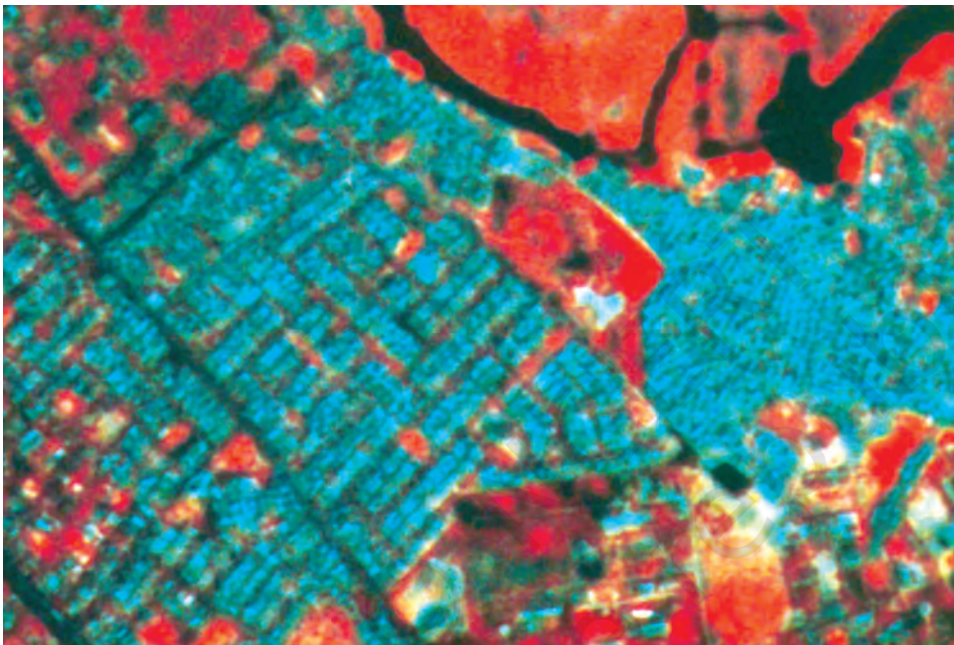

Figure 6.17 Planned residential areas are easily identifiable using the pattern they form

**7. Association:** The association refers to the relationship between the objects and their surroundings along with their geographical location. For example, an educational institution always finds its association with its location in or near a residential area as well as the location of a playground within the same premises. Similarly, stadium, race course and golf course holds good for a large city, industrial sites along highway at the periphery of a growing city, and slums along drains and railway lines.

Internet sources for more information:

- [www.isro.gov.in](http://www.isro.gov.in)
- [www.nrsc.gov.in](http://www.nrsc.gov.in)
- [www.iirs.gov.in](http://www.iirs.gov.in)

**EXERCISE**

1. Choose the right answer from the four alternatives given below
  - (i) Remote sensing of objects can be done through various means such as A. remote sensors, B. human eyes and C. photographic system. Which of the following represents the true order of their evolution.
    - (a) ABC
    - (b) BCA
    - (c) CAB
    - (d) None of the above
  - (ii) Which of the following regions of Electromagnetic spectrum is not used in satellite remote sensing.
    - (a) Microwave region
    - (b) Infrared region
    - (c) X - rays
    - (d) Visible region
  - (iii) Which of the following is not used in visual interpretation technique ?
    - (a) Spatial arrangements of objects
    - (b) Frequency of tonal change on the image
    - (c) Location of objects with respect to other objects
    - (d) Digital image processing
2. Answer the following questions in about 30 words.
  - (i) Why is remote sensing a better technique than other traditional methods?
  - (ii) Differentiate between IRS and INSAT series of satellites.
  - (iii) Describe in brief the functioning of pushbroom scanner.
3. Answer the following questions in about 125 words.
  - (i) Describe the operation of a whiskbroom scanner with the help of a diagram. Explain how it is different from pushbroom scanner.
  - (ii) Identify and list the changes that can be observed in the vegetation of Himalayas (Fig.6.9).

### ACTIVITY

Identify various features marked on IRS IC LISS III imagery shown below. Draw clues from the description of the elements of image interpretation discussed and the colours in which various objects appear on a Standard False Colour Composite.

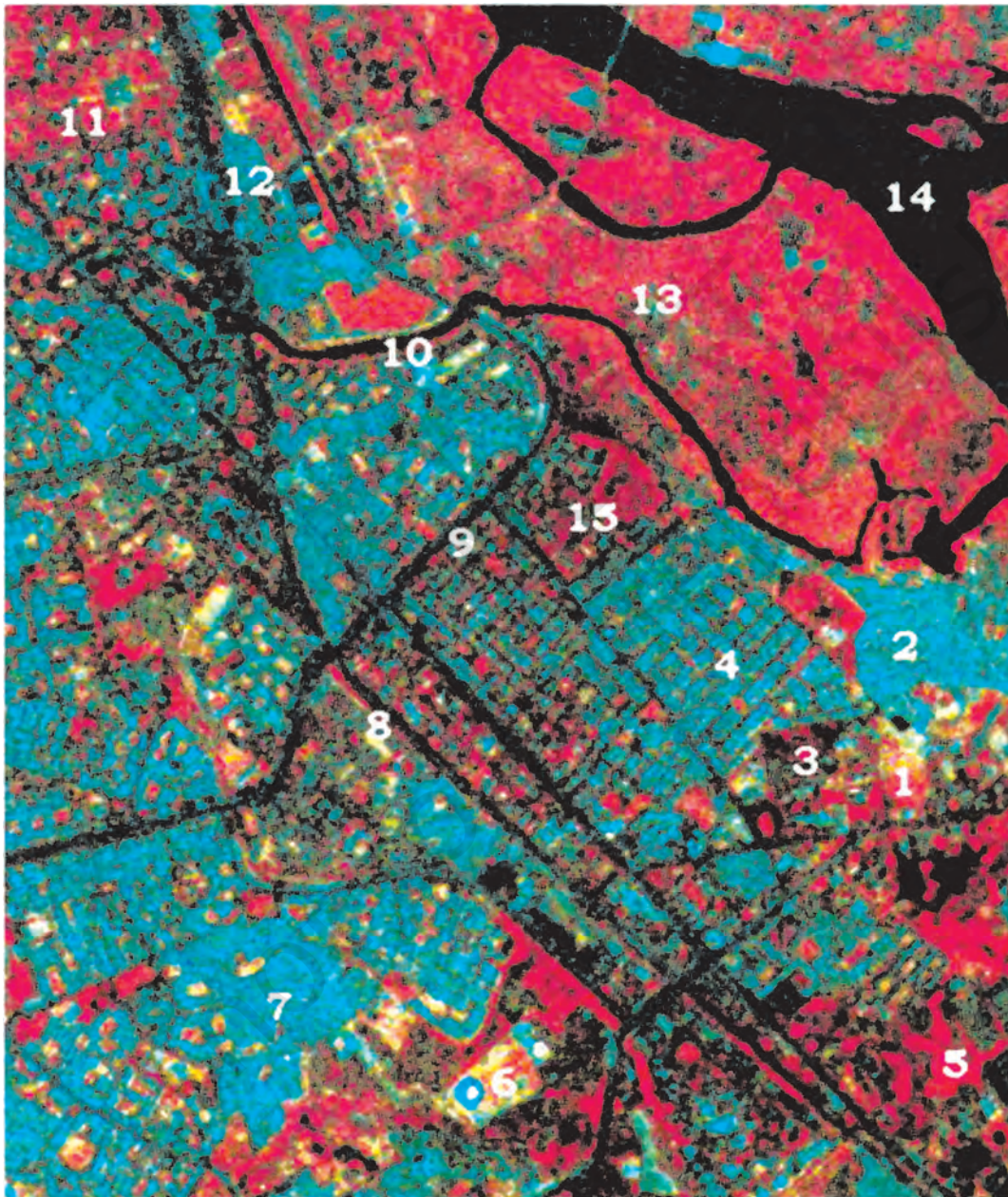

NOTES

© NCERT  
not to be republished